



**REBATED BEVELBACK  
WEATHERBOARD  
CLADDING SPECIFICATION**



**SUPPLIERS OF AUSTRALIAN  
HARDWOOD TIMBER SOLUTIONS  
*THAT DON'T COST THE EARTH***

## **SPECIFICATION CONTENTS**

### **PAGE(S)**

03	<i>LMA TIMBER WEATHERBOARD OVERVIEW</i>
04 - 05	<i>pass™: LMA TIMBER HARDWOOD HORIZONTAL SHIPLAP</i>
06	<i>SUPPORTING DOCUMENTATION FOR ALTERNATIVE SOLUTION</i>
07 - 35	<i>NON-REBATED BEVELBACK WEATHERBOARD DETAILING</i>
36 - 39	<i>INSTALLATION GUIDE AND MAINTENANCE GUIDE</i>
40 - 44	<i>DURABILITY REPORT (CLASS 1 HARDWOOD)</i>
47 - 115	<i>DURABILITY SUPPORTING DOCUMENTS</i>
116 - 119	<i>SPECIES DATA SHEETS</i>
120	<i>SCREW SPECIFICATION</i>
121 - 124	<i>PENETRATING OIL SPECIFICATION</i>



## **LMA TIMBER WEATHERBOARD - OVERVIEW**

LMA Timbers hardwood cladding solutions are a mix of class 1 (40 year plus durability) Australian hardwood timbers that have been milled in accordance with NZS 3617 Branz Bulletin 411. These timbers include Grey / Red Iron Bark, Tallowwood, and Spotted Gum. Specifications for all of these timbers are included in this document.

The timber species is Australian Eucalyptus Class 1 hardwood - not to be confused with New Zealand Eucalyptus which is a lot softer and is generally a class 3 timber. The hardwood cladding is kiln dried to between 9-14% moisture (to meet MPI guidelines) and is milled to precision allowing for a superior finish / minimal movement compared to other timber cladding options.

The claddings durability has also been confirmed by Tripti Singh – Scientist at Scion Research – along with copious documentation and research around the world using the Class 1 to 4 System in stating a timbers natural durability.

Building consents have been issued all over New Zealand for the hardwood cladding as an alternative cladding solution. CodeMark / Branz appraisal is currently being pursued. Example Council Consents of BCN\_2018\_4315 (Christchurch Council), BC161351 (Waimakariri Council) BC182180 (Selwyn Council) and BCO10313586 (Auckland Council) where the hardwood has been used as a primary cladding as an alternative build solution.

Many comparisons are always made between our hardwood cladding and Western Red Cedar so below is a link to the wood solutions page below which has all the specifications on both Cedar and Grey Iron Bark.

By comparing key properties of the two - Grey Iron Bark for example is naturally more durable (>40 years vs 7-15 years for Cedar), higher in density (1120kg/M3 vs 350Kgs M3) and stronger (F27-34 vs F8). The timber is still classified as a light weight cladding coming in at between 23 and 25kgs per m2.

Western Red Cedar

<https://www.woodsolutions.com.au/Wood-Species/Western-Red-Cedar>

Grey Iron Bark

<https://www.woodsolutions.com.au/wood-species/ironbark-grey>

For further information, please get in contact with the Managing Director of LMA Timber - Martin Thompson on 021 398 800 or email [martin@lmatimber.co.nz](mailto:martin@lmatimber.co.nz)

# LMA TIMBER HARDWOOD HORIZONTAL WEATHERBOARD SYSTEM

## PURPOSE

LMA Timber supplies the Hardwood Horizontal Weatherboard system for use as an external cladding system. The system comprises weatherboards, external corner moulds, internal corner moulds, cover battens, scribes, eave moulds, and fixing screws.

## EXPLANATION

LMA Timber's Hardwood Horizontal Weatherboard timbers are milled from a mixture of Australian and Fijian hardwood timbers that are classified as Class 1 and Class 2 natural durability under AS 5604-2005.

Timbers used include Grey/Red Iron Bark, Tallowwood, Blackbutt, Fijian Mahogany, Silvertop Ash and Spotted Gum. The timber is kiln-dried to a moisture content of between 9–14% before being factory coated with Intergrain Universal Timber Oil for further durability. Clad Lap joints and ends must be sealed with oil before installation.

The weatherboard profiles of Shiplap, Rusticated, Rebated bevelback and Non-rebated bevelback are in accordance with NZS 3617:1979 and BRANZ Bulletin 411, with installation in accordance with LMA Timber details incorporating a drained and ventilated cavity and a flashing system that meets the requirements of Acceptable Solution E2/AS1.

The weatherboards come with a dressed or sawn finish and the following effective covers:

- 165 mm – Shiplap, Rusticated, Rebated bevelback, Non-rebated bevelback
- 115 mm – Shiplap, Rusticated and Rebated bevelback
- 108 mm – Non-rebated bevelback.

## SCOPE AND LIMITATIONS OF USE

Scope	Limitations
<b>Location</b> In wind zones up to and including extra high as defined in NZS 3604:2011 or to a design wind pressure (ULS) of 2.1 kPa. In all exposure zones as defined in NZS 3604:2011. At least 1 m from a relevant or notional boundary.	➤ Use in microclimatic conditions, as defined in NZS 3604:2011, is excluded. ➤ Fixings must be Würth ASSY® plus A2 decking screw or in accordance with Table C.3.1.1 of E2/AS1.
<b>Building</b> In conjunction with a primary structure that complies with the NZ Building Code or existing buildings where the designer and/or installer have satisfied themselves that the existing building is suitable for the intended building work. On timber or lightweight steel-framing. As an external cladding system.	➤ A thermal break must be installed if the framing is lightweight steel. ➤ The building must be within the scope of paragraph 1.1 of E2/AS1. ➤ The building must be less than 10 m in building height. ➤ The building must have a risk score of less than or equal to 20 when evaluated against the E2/AS1 risk matrix. ➤ The cladding must be installed over a drained and ventilated cavity. ➤ In conjunction with a flexible building wrap or rigid underlay in accordance with Clauses 9.1.5 to 9.1.7 of E2/AS1 that meets the requirements of Table C.2.1.1 or is a proprietary product with a current Product Certificate. ➤ With joinery that meets the requirements of NZS 4211.

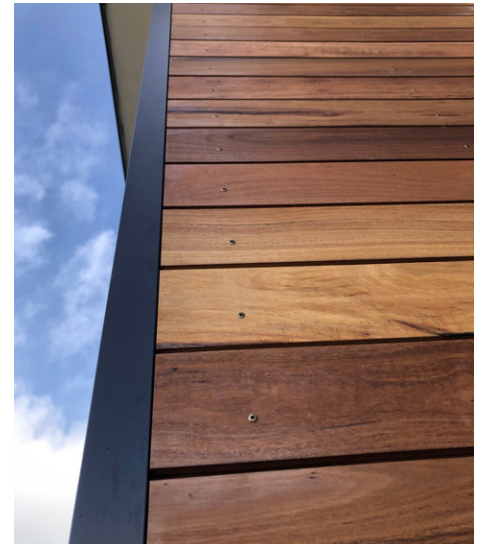

For further assistance please contact:

- ☎ 021 398 800
- ✉ info@lmatimber.co.nz
- 🌐 [lmatimber.co.nz](http://lmatimber.co.nz)

## USEFUL INFORMATION

For design, installation and maintenance information, refer to [lmatimber.co.nz](http://lmatimber.co.nz).

## PERFORMANCE CLAIMS

If designed, installed, and maintained in accordance with all LMA Timber requirements, the Hardwood Horizontal Weatherboard system will comply with or contribute to compliance with the following performance claims:

NZ Building Code clauses	BASIS OF COMPLIANCE	
	Compliance statement	Demonstrated by
<b>B1 STRUCTURE</b> B1.3.1, B1.3.2, B1.3.3 (a, e, f, h, j, m, q, and in respect of UV radiation), B1.3.4 (a, b, c, d)	ALTERNATIVE SOLUTION	<ul style="list-style-type: none"> <li>Dimensions – profiles in accordance with NZS 3617:1979. Paragraph 104.1.1 of NZS 3602:2003 (cited in NZS 3604:2011, cited in Acceptable Solution B1/ AS1) and paragraph 5.1 of NZS 3617:1979 for the required dimensions of weatherboards [LMA Timber, n.d.a; n.d.b; n.d.c; n.d.d].</li> <li>Strength grade F22/F27 to NZS 3618-1:1984 has significantly greater strength than NZS 3602:2003 materials (e.g., radiata pine) [LMA Timber, n.d.a; n.d.b; n.d.c; n.d.d].</li> </ul>
<b>B2 DURABILITY</b> B2.3.1(b)	VERIFICATION METHOD B2/VM1	<ul style="list-style-type: none"> <li>Durability assessment by timber durability expert concludes durability requirements are met, based on durability testing and 26 year in-service history in Australia [University of Sunshine Coast, 05/07/2021].</li> <li>Class 1 and 2 durability to AS 5604-2005 [Timber Queensland, 03/2014].</li> <li>Durability assessment concludes the hardwood used and its moisture content is comparable to H3.1 treated timber as per NZS 3602:2003 Table 2A [ADarchitecture, n.d.].</li> </ul>
<b>E2 EXTERNAL MOISTURE</b> E2.3.2, E2.3.3, E2.3.5, E2.3.7 (a, b, c)	ALTERNATIVE SOLUTION	<ul style="list-style-type: none"> <li>Profiles in accordance with NZS 3617:1979, cited in E2/AS1, paragraph 9.4.1.1 [LMA Timber, n.d.a; n.d.b; n.d.c; n.d.d].</li> <li>Rusticated weatherboard system and Bevelback Weatherboard system installation details in accordance with E2/AS1 [LMA Timber, n.d.a; n.d.b; n.d.c].</li> <li>Horizontal Shiplap weatherboard weathergroove and half housing joint comparable to rusticated weatherboard [LMA Timber, n.d.d].</li> <li>Horizontal Shiplap weatherboard system installation details identical to E2/AS1 Rusticated weatherboard system details [LMA Timber, n.d.d].</li> </ul>
<b>F2 HAZARDOUS BUILDING MATERIALS</b> F2.3.1	ALTERNATIVE SOLUTION	<ul style="list-style-type: none"> <li>Timber is untreated.</li> <li>Oil finish claimed not dangerous by manufacturer with V.O.C. &lt;605 g/l [Intergrain, 13/03/2020].</li> <li>Use in accordance with supplier's instructions.</li> </ul>

## SOURCES OF INFORMATION

- LMA Timber. [n.d.a] *Rusticated Shiplap Weatherboard Cladding Specification*.
- LMA Timber. [n.d.b] *Rebated Bevelback Weatherboard Cladding Specification*.
- LMA Timber. [n.d.c] *Non Rebated Bevelback Weatherboard Cladding Specification*.
- LMA Timber. [n.d.d] *Horizontal Shiplap Weatherboard Cladding Specification*.
- Timber Queensland. [03/2014] *Technical Data Sheet - Species, Properties, and Uses - 16B*.
- ADarchitecture. [n.d.] *Supporting documentation for Alternative Solution to NZBC:B2 & E2 Australian Hardwood Timbers (e.g Spotted Gum Grey Iron Bark) to achieve 15 year durability for use as Vertical Shiplap weatherboards on cavity*.
- University of Sunshine Coast. [05/07/2021] *Australian Hardwood Cladding*.
- Intergrain. [13/03/2020] *Datasheet - Intergrain Universal Timber Oil Matt*. Document no. AU\_DW02675. Version 1.0.

SCAN OR CLICK THIS QR CODE TO ACCESS OR REQUEST THE RELEVANT SUPPORTING DOCUMENTATION FOR THIS PASS™.

[lmatimber.co.nz/cladding/](http://lmatimber.co.nz/cladding/)



1. Where a standard is referenced it is to be read as amended by the acceptable solution or verification method as applicable. 2. Sources of information also include the Building Act 2004 and its regulations, including the Building Code (Schedule 1 of the Building Regulations 1992), Acceptable Solutions and Verification Methods, and relevant cited standards. 3. The product is not subject to a warning or ban under section 26 of the Building Act. 4. For overseas manufacturer details, where applicable, refer to the company that is the holder of this pass™. 5. The quality and assurance that the supplied products meet the performance claims stated in this pass™ are the responsibility of the company that is the holder of this pass™. 6. The availability of the information about the supplied products required to be disclosed under s14G(3) is the responsibility of the company that is the holder of this pass™.

LMA Timber Ltd confirms that if the Hardwood Horizontal Cladding system is used in accordance the requirements of this pass™ the product will comply with the NZ Building Code and other performance claims set out in this pass™ and the company has met all of its obligations under s14G(2) of the Building Act.

**Date of first issue:** 17/05/2023

**Date of current issue:** 20/05/2026

**NZBN:** 9429046749680

Kevin Brunton

Kevin Brunton, Technical Director, TBB confirms that the process used to prepare this pass™ on behalf of LMA Timber Ltd has been undertaken in accordance with MBIE PTS guidelines and in accordance with the TBB pass™ process which is within the scope of TBB's ISO 9001 certification.

90566D6A68E04C0DCA258AB4001045C0

66 Wickham Street, Bromley, Christchurch 8062 > [info@lmatimber.co.nz](mailto:info@lmatimber.co.nz) > 021 398 800 > [lmatimber.co.nz](http://lmatimber.co.nz)

Copyright © 2017, The Building Business Limited (TBB). All rights reserved.

## Supporting documentation for Alternative Solution to NZBC:B2 & E2 Australian Hardwood Timbers (e.g Spotted Gum Grey Iron Bark) to achieve 15 year durability for use as Vertical / Horizontal Shiplap weatherboards on cavity

Several references are used to illustrate compliance:

1. Comparison with NZBC Acceptable Solution B2/AS1. 1.
2. Comparison with Timber Queensland “Species, Properties and Uses” TDS 16a and 16b
3. Commentary on NZBC Acceptable Solution E2/AS1.
4. Reference to alternative solutions provided by other weatherboard suppliers
5. Reference to previous Consent issued

Timber: Class 1 Australian Eucalyptus such as Spotted Gum, Iron Bark (Red & Grey), Tallowwood, White Mahogany, Blackbutt - HEARTWOOD

Location: Weatherboards

Durability requirement: 15 Years

Means of compliance: Comparison with TDS16a and TDS16b cypress species (acceptable solution) with a durability class 1 (above ground) >40 years. Heart timber comparable with Lawson Cypress/ Pinus Radiata treated to H3.1 (Table 2A NZS 3602:2003)

Protection: none required (as per Clause 111.2.5 NZS 3602:2003) Suggest application of Dulux Intragrain or similar wood oil be used to retain colour and appearance. 1 coat factory applied plus 1 coat after installation.

NZBC E2/AS1 only provides an acceptable solution for direct fix vertical shiplap weatherboard cladding. A cavity solution was not included primarily because at the time of publication, castellated battens were not available or at least not widely used.

The desire from most architects and designers, as well as insurance companies, is to provide a cavity solution for cladding as this provides a greater degree of protection. Cavity installations can have a high score using the NZBC E2 Risk Matrix. It is therefore logical to assume that vertical shiplap weatherboards fitted over a cavity meet the requirements of NZBC E2 as an alternative solution. Castellated structural cavity battens are now widely available to enable the appropriate installation of vertical shiplap weatherboards.

There are several suppliers with approved alternative solutions for Vertical and Horizontal Shiplap weatherboards on cavity (e.g. Hermpac, Abodo, JSC and Rosenfeld Kidson). It is reasonable to assume that that LMA timber weatherboards also comply given the installation methodology (including fixings and flashings) is fundamentally the same.

As further evidence of acceptability, the Kapiti Coast District Council has previously issued a consent for Vertical Shiplap weatherboards on cavity. Refer to BC 210518 - 123Manly St, Paraparaumu Beach.

1. Scope as per Clauses 1.0 and 9.4 E2/AS1
2. Profiles as per NZS 3617 Branz Bulletin 411
3. Fixings as per Table 24 E2/AS1
4. Compatibility of materials as per Tables 20-22 E2/AS1
5. Flashing as per Clause 4.0 E2/AS1
6. Rigid and flexible underlay as per Table 23 and Clauses 9.1.5 to 9.1.7 E2/AS1 or proprietary approved alternative
7. The weatherboard system relies on the joinery meeting the requirements of NZS 4211 for the relevant building wind zone or wind pressure



## LMA BEVELBACK HARDWOOD CLADDING DRAWING INDEX

Product	Sheet No.	Sheet Name	Issue Date
LMA	BEV_00	Bevelback Hardwood Cladding Profile	03/2020
LMA	BEV_01	Window Head Detail_Aluminium Joinery	03/2020
LMA	BEV_02	Window Sill Detail_Aluminium Joinery	03/2020
LMA	BEV_03	Window Jamb Detail_Aluminium Joinery	03/2020
LMA	BEV_04	Door Head Detail_Aluminium Joinery	03/2020
LMA	BEV_05	Door Sill Detail_Aluminium Joinery	03/2020
LMA	BEV_06	Door Jamb Detail_Aluminium Joinery	03/2020
LMA	BEV_07	Internal Corner_Mould	03/2020
LMA	BEV_08	Internal Corner_Scribed	03/2020
LMA	BEV_09	Internal Corner_Boxed	03/2020
LMA	BEV_10	External Corner_Boxed	03/2020
LMA	BEV_11	External Corner_Soaker	03/2020
LMA	BEV_12	Enclosed Deck Balustrade to Wall Junction	03/2020
LMA	BEV_13	Parapet Detail	03/2020
LMA	BEV_14	Cavity at Enclosed Deck	03/2020
LMA	BEV_15	Drained Inter-Storey Joint	03/2020
LMA	BEV_16	Base of Wall_Concrete	03/2020
LMA	BEV_17	Base of Wall_Timber	03/2020
LMA	BEV_18	Scarf Join Stain Finish	03/2020
LMA	BEV_19	Roof/Wall Junction	03/2020
LMA	BEV_20	Soffit Detail_Overhang	03/2020
LMA	BEV_21	Eaves Detail_No Overhang	03/2020
LMA	BEV_22	Meter Box Detail	03/2020
LMA	BEV_23	General Nail fixing_Stain Finish	03/2020
LMA	BEV_24	General Nail Fixing_Paint Finish	03/2020
LMA	BEV_25	Pipe Penetration Plan Detail	03/2020
LMA	BEV_26	Pipe Penetration Detail	03/2020
LMA	BEV_27	Battens Set Out	03/2020



### Contact Details

P: 021 398 800  
 E: info@lmatimber.co.nz  
 W: www.lmatimber.co.nz  
 A: 281 Dyers Road, Bromley, 8062

• TITLE: LMA Bevelback Hardwood Cladding

• DRAWING: **Cover sheet**

• SCALE: @A4

• DATE:06/03/2020

1. Scope as per Clauses 1.0 and 9.4 E2/AS1
2. Profiles as per NZS 3617 Branz Bulletin 411
3. Fixings as per Table 24 E2/AS1
4. Compatibility of materials as per Tables 20-22 E2/AS1
5. Flashing as per Clause 4.0 E2/AS1
6. Rigid and flexible underlay as per Table 23 and Clauses 9.1.5 to 9.1.7 E2/AS1 or proprietary approved alternative
7. The weatherboard system relies on the joinery meeting the requirements of NZS 4211 for the relevant building wind zone or wind pressure

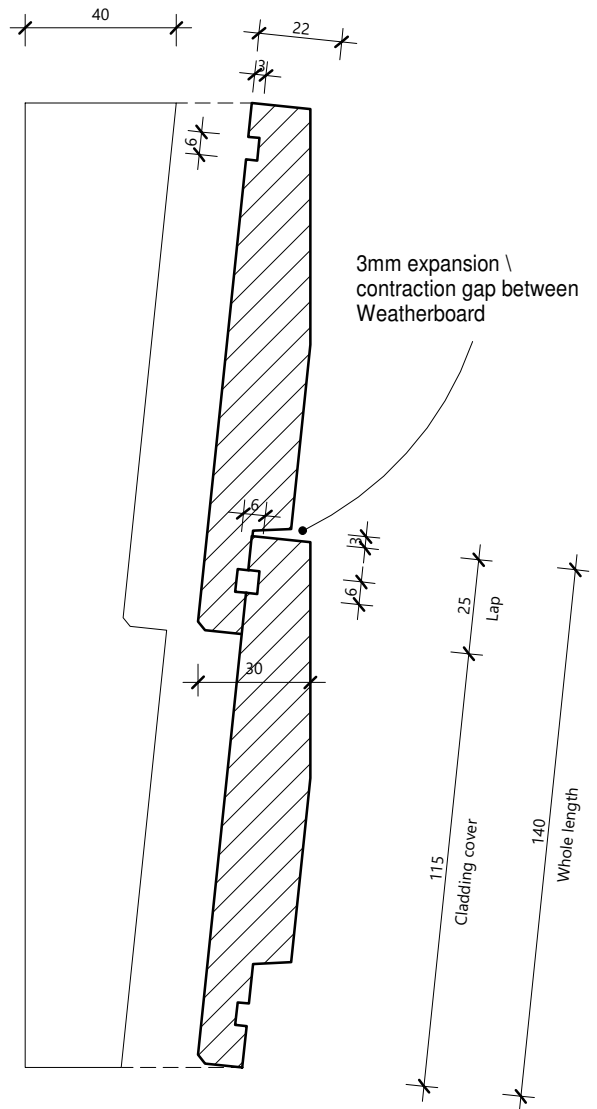
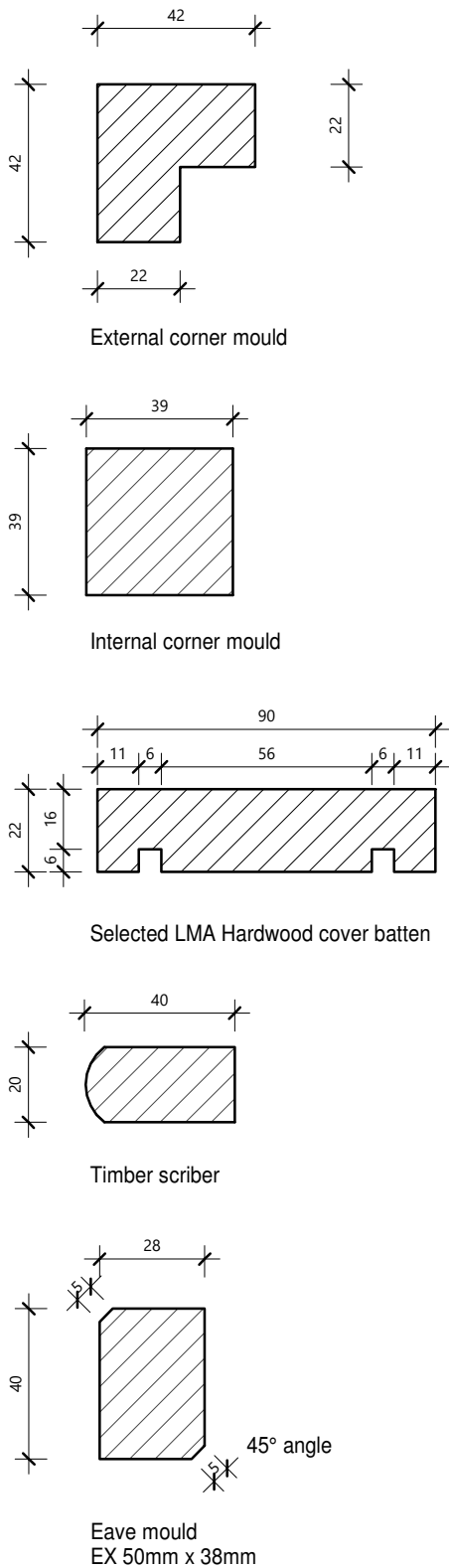

Timber scriber

LMA Bevelback hardwood cladding 114mm cover



Wurth ASSY plus A2 decking screw or as per E2/AS1 - Table 24

### Contact Details

P: 021 398 800  
E: info@lmatimber.co.nz  
W: www.lmatimber.co.nz  
A: 281 Dyers Road, Bromley, 8062

• TITLE: LMA Bevelback Hardwood Cladding

• DRAWING: Bevelback Hardwood Cladding Profile

• SCALE: 1 : 2@A4

• DATE: 06/03/2020

1. Scope as per Clauses 1.0 and 9.4 E2/AS1
2. Profiles as per NZS 3617 Branz Bulletin 411
3. Fixings as per Table 24 E2/AS1
4. Compatibility of materials as per Tables 20-22 E2/AS1
5. Flashing as per Clause 4.0 E2/AS1
6. Rigid and flexible underlay as per Table 23 and Clauses 9.1.5 to 9.1.7 E2/AS1 or proprietary approved alternative
7. The weatherboard system relies on the joinery meeting the requirements of NZS 4211 for the relevant building wind zone or wind pressure

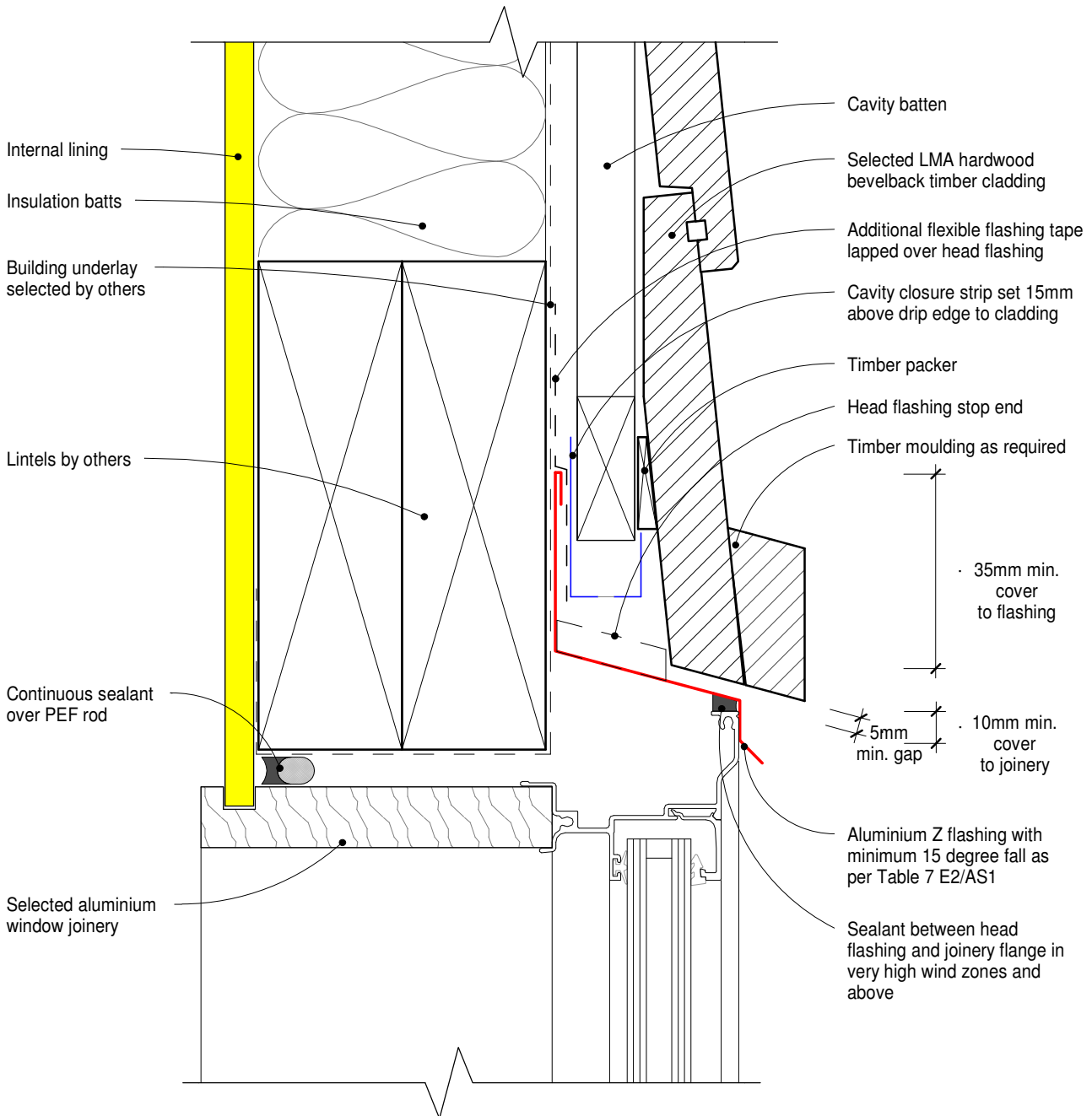
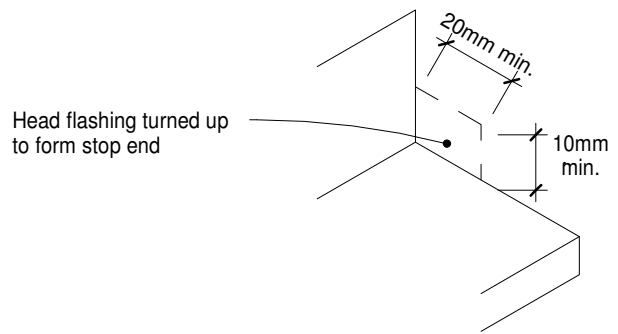

### Contact Details

P: 021 398 800  
E: info@lmatimber.co.nz  
W: www.lmatimber.co.nz  
A: 281 Dyers Road, Bromley, 8062

• TITLE: LMA Bevelback Hardwood Cladding

• DRAWING: Window Head Detail\_Aluminium Joinery

• SCALE: 1 : 2@A4

• DATE:06/03/2020

1. Scope as per Clauses 1.0 and 9.4 E2/AS1
2. Profiles as per NZS 3617 Branz Bulletin 411
3. Fixings as per Table 24 E2/AS1
4. Compatibility of materials as per Tables 20-22 E2/AS1
5. Flashing as per Clause 4.0 E2/AS1
6. Rigid and flexible underlay as per Table 23 and Clauses 9.1.5 to 9.1.7 E2/AS1 or proprietary approved alternative
7. The weatherboard system relies on the joinery meeting the requirements of NZS 4211 for the relevant building wind zone or wind pressure

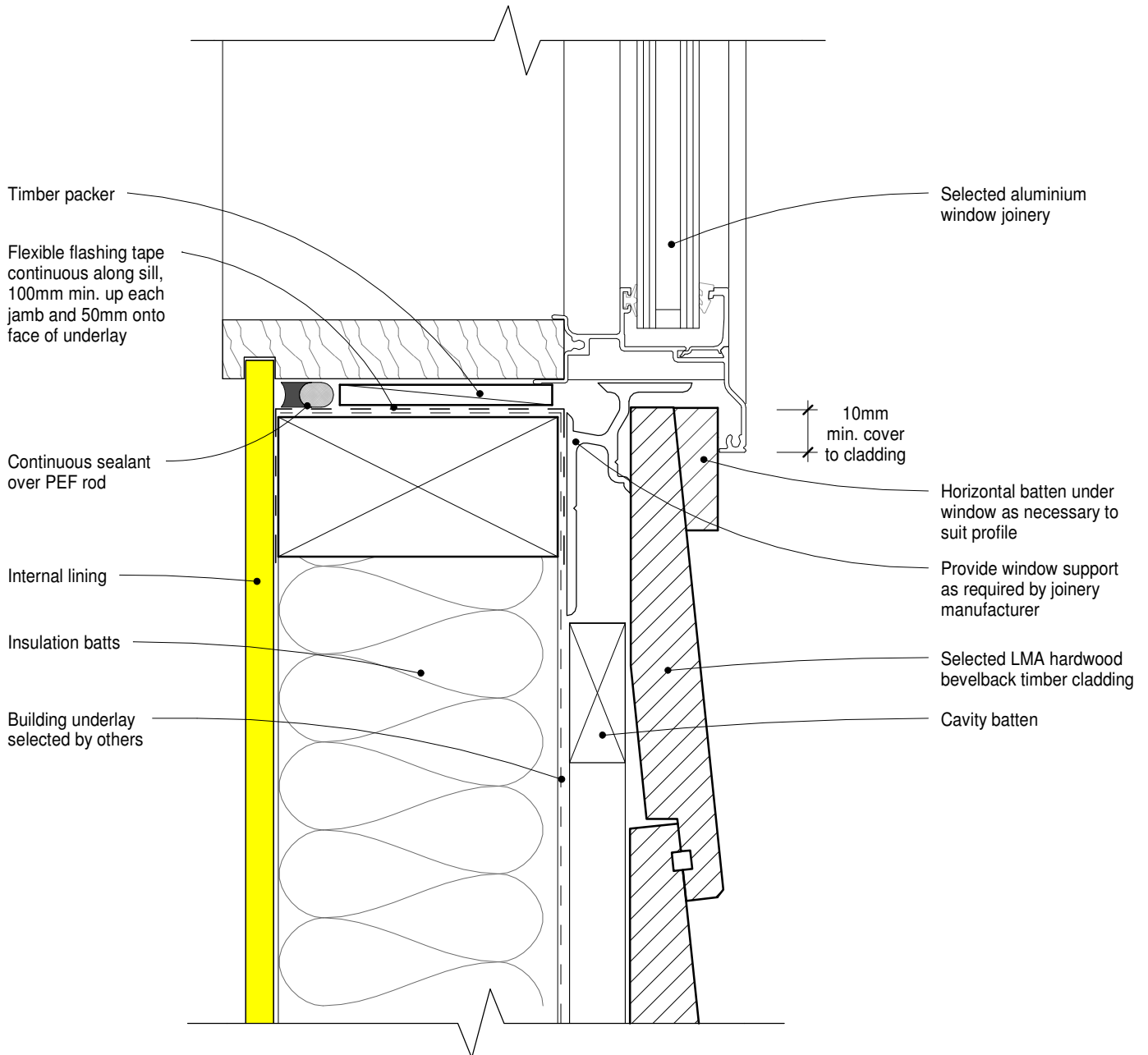

### Contact Details

P: 021 398 800  
 E: info@lmatimber.co.nz  
 W: www.lmatimber.co.nz  
 A: 281 Dyers Road, Bromley, 8062

• TITLE: LMA Bevelback Hardwood Cladding

• DRAWING: Window Sill Detail\_Aluminium Joinery

• SCALE: 1 : 2@A4

• DATE:06/03/2020

1. Scope as per Clauses 1.0 and 9.4 E2/AS1
2. Profiles as per NZS 3617 Branz Bulletin 411
3. Fixings as per Table 24 E2/AS1
4. Compatibility of materials as per Tables 20-22 E2/AS1
5. Flashing as per Clause 4.0 E2/AS1
6. Rigid and flexible underlay as per Table 23 and Clauses 9.1.5 to 9.1.7 E2/AS1 or proprietary approved alternative
7. The weatherboard system relies on the joinery meeting the requirements of NZS 4211 for the relevant building wind zone or wind pressure

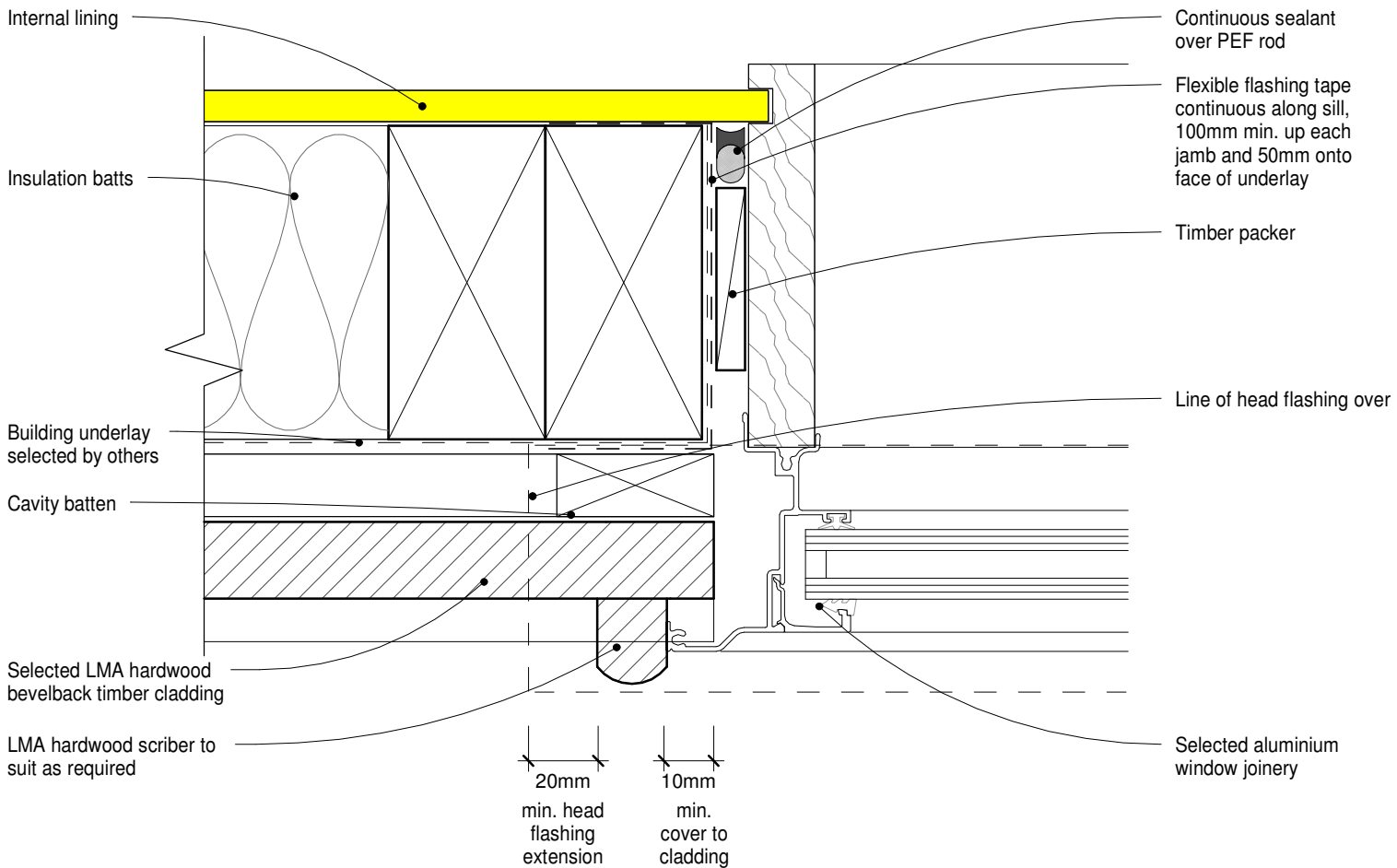

### Contact Details

1. Scope as per Clauses 1.0 and 9.4 E2/AS1
2. Profiles as per NZS 3617 Branz Bulletin 411
3. Fixings as per Table 24 E2/AS1
4. Compatibility of materials as per Tables 20-22 E2/AS1
5. Flashing as per Clause 4.0 E2/AS1
6. Rigid and flexible underlay as per Table 23 and Clauses 9.1.5 to 9.1.7 E2/AS1 or proprietary approved alternative
7. The weatherboard system relies on the joinery meeting the requirements of NZS 4211 for the relevant building wind zone or wind pressure

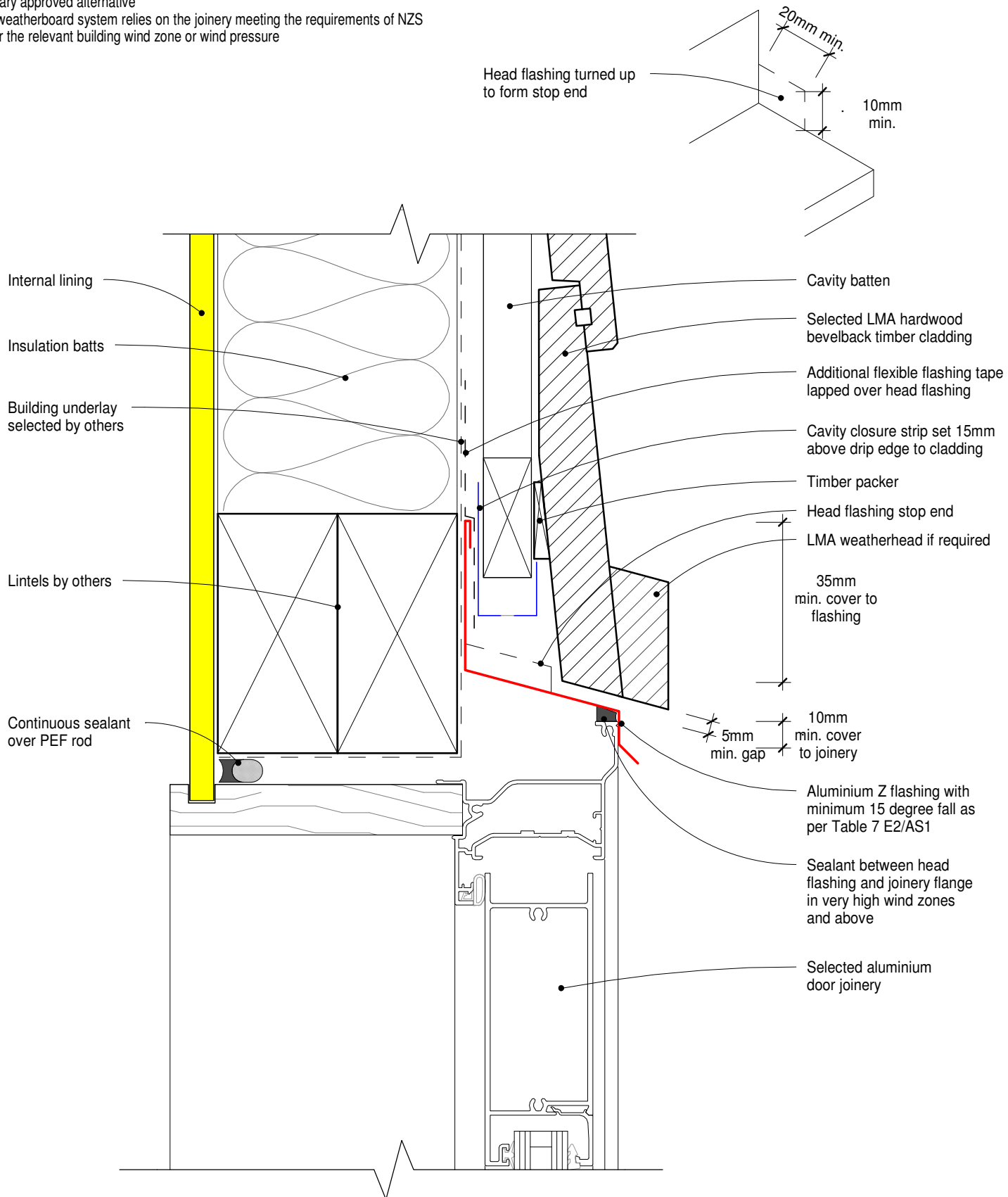

### Contact Details

P: 021 398 800  
E: info@lmatimber.co.nz  
W: www.lmatimber.co.nz  
A: 281 Dyers Road, Bromley, 8062

• TITLE: LMA Bevelback Hardwood Cladding	
• DRAWING: Door Head Detail_Aluminium Joinery	
• SCALE: 1 : 2@A4	• DATE:06/03/2020

1. Scope as per Clauses 1.0 and 9.4 E2/AS1
2. Profiles as per NZS 3617 Branz Bulletin 411
3. Fixings as per Table 24 E2/AS1
4. Compatibility of materials as per Tables 20-22 E2/AS1
5. Flashing as per Clause 4.0 E2/AS1
6. Rigid and flexible underlay as per Table 23 and Clauses 9.1.5 to 9.1.7 E2/AS1 or proprietary approved alternative
7. The weatherboard system relies on the joinery meeting the requirements of NZS 4211 for the relevant building wind zone or wind pressure

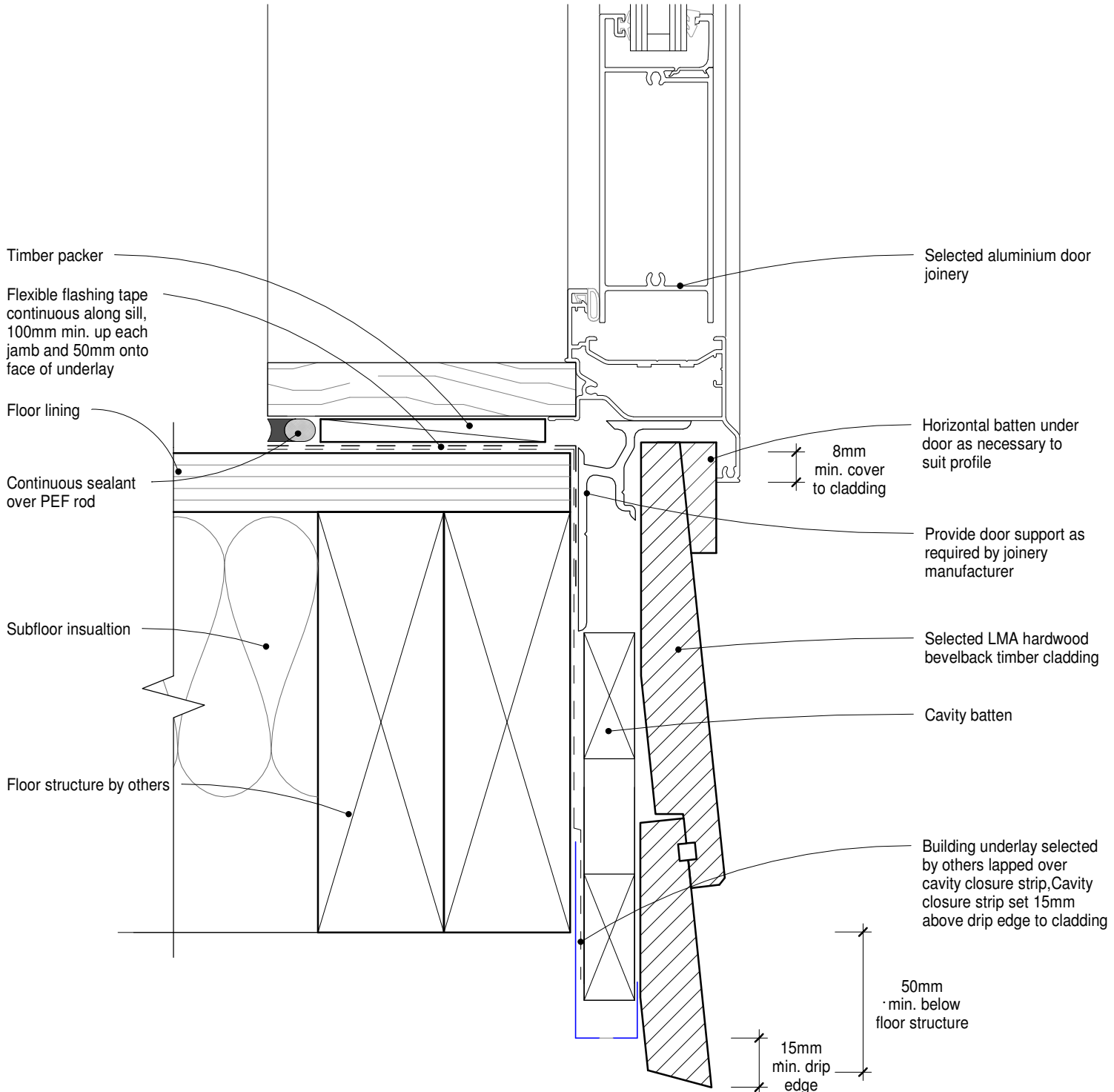

### Contact Details

P: 021 398 800  
E: info@lmatimber.co.nz  
W: www.lmatimber.co.nz  
A: 281 Dyers Road, Bromley, 8062

• TITLE: LMA Bevelback Hardwood Cladding

• DRAWING: Door Sill Detail\_Aluminium Joinery

• SCALE: 1 : 2@A4

• DATE: 06/03/2020

1. Scope as per Clauses 1.0 and 9.4 E2/AS1
2. Profiles as per NZS 3617 Branz Bulletin 411
3. Fixings as per Table 24 E2/AS1
4. Compatibility of materials as per Tables 20-22 E2/AS1
5. Flashing as per Clause 4.0 E2/AS1
6. Rigid and flexible underlay as per Table 23 and Clauses 9.1.5 to 9.1.7 E2/AS1 or proprietary approved alternative
7. The weatherboard system relies on the joinery meeting the requirements of NZS 4211 for the relevant building wind zone or wind pressure

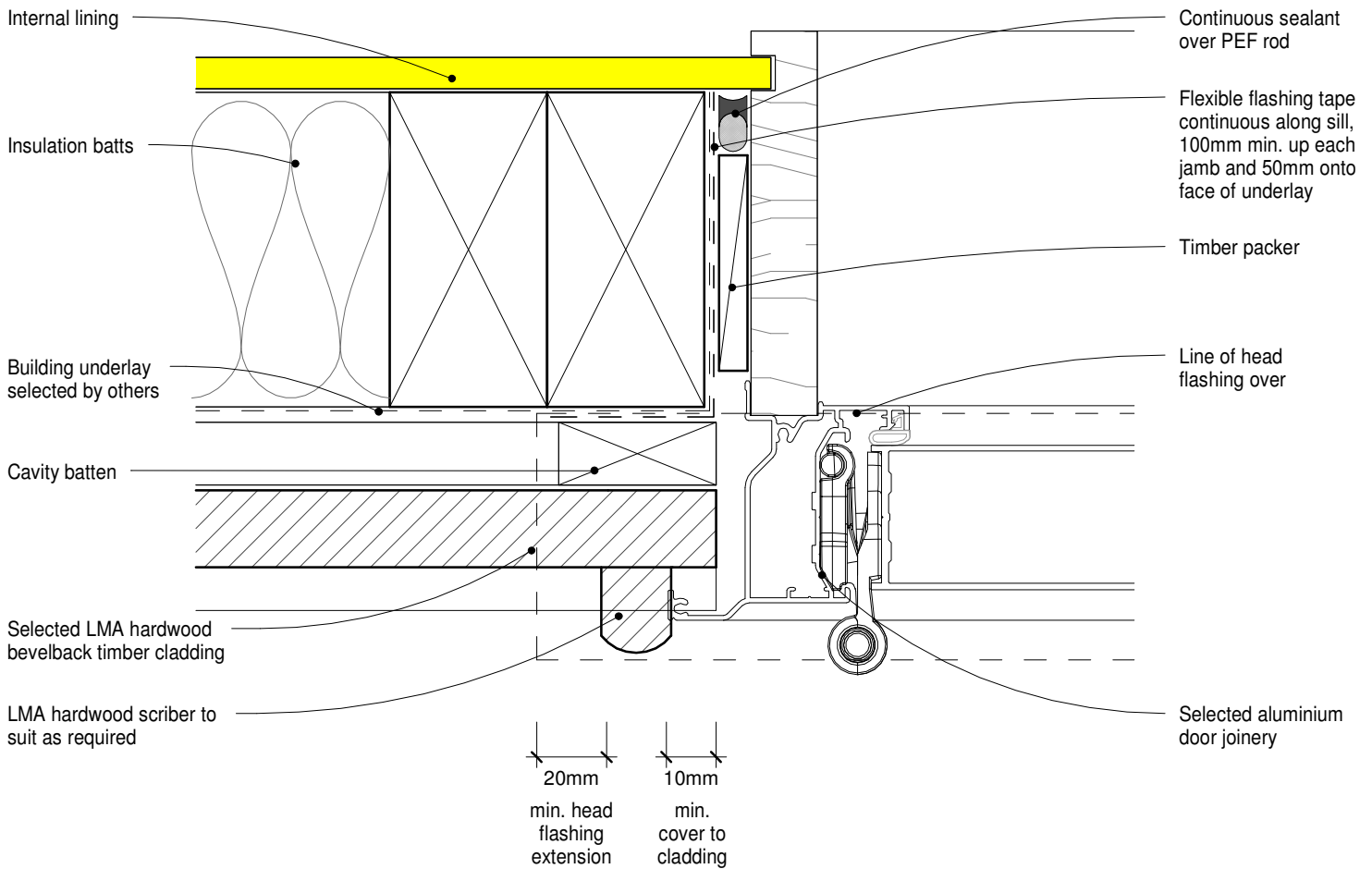

### Contact Details

1. Scope as per Clauses 1.0 and 9.4 E2/AS1
2. Profiles as per NZS 3617 Branz Bulletin 411
3. Fixings as per Table 24 E2/AS1
4. Compatibility of materials as per Tables 20-22 E2/AS1
5. Flashing as per Clause 4.0 E2/AS1
6. Rigid and flexible underlay as per Table 23 and Clauses 9.1.5 to 9.1.7 E2/AS1 or proprietary approved alternative
7. The weatherboard system relies on the joinery meeting the requirements of NZS 4211 for the relevant building wind zone or wind pressure

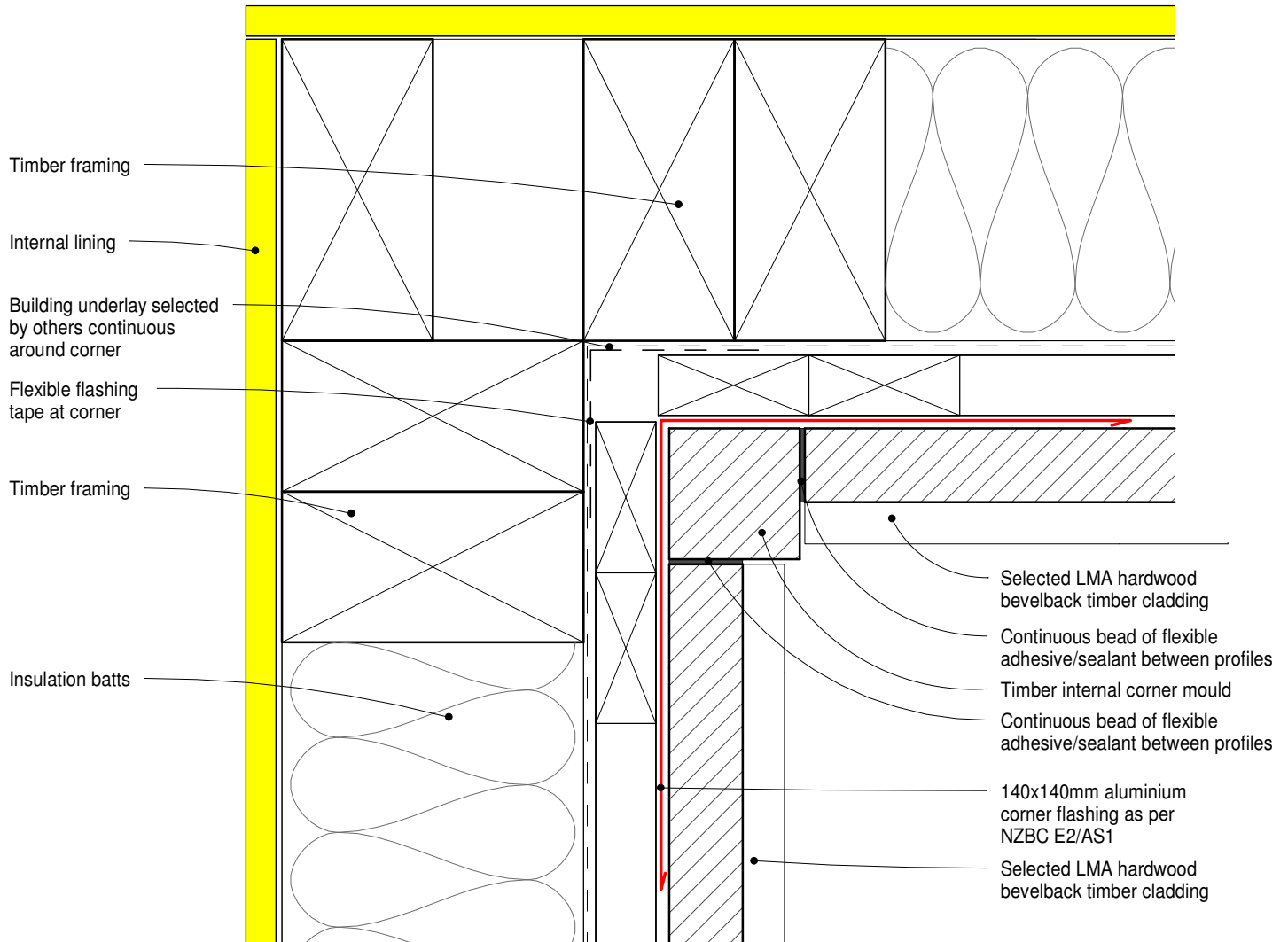

### Contact Details

P: 021 398 800  
E: info@lmatimber.co.nz  
W: www.lmatimber.co.nz  
A: 281 Dyers Road, Bromley, 8062

• TITLE: LMA Bevelback Hardwood Cladding

• DRAWING: Internal Corner\_Mould

• SCALE: 1 : 2@A4

• DATE:06/03/2020

1. Scope as per Clauses 1.0 and 9.4 E2/AS1
2. Profiles as per NZS 3617 Branz Bulletin 411
3. Fixings as per Table 24 E2/AS1
4. Compatibility of materials as per Tables 20-22 E2/AS1
5. Flashing as per Clause 4.0 E2/AS1
6. Rigid and flexible underlay as per Table 23 and Clauses 9.1.5 to 9.1.7 E2/AS1 or proprietary approved alternative
7. The weatherboard system relies on the joinery meeting the requirements of NZS 4211 for the relevant building wind zone or wind pressure

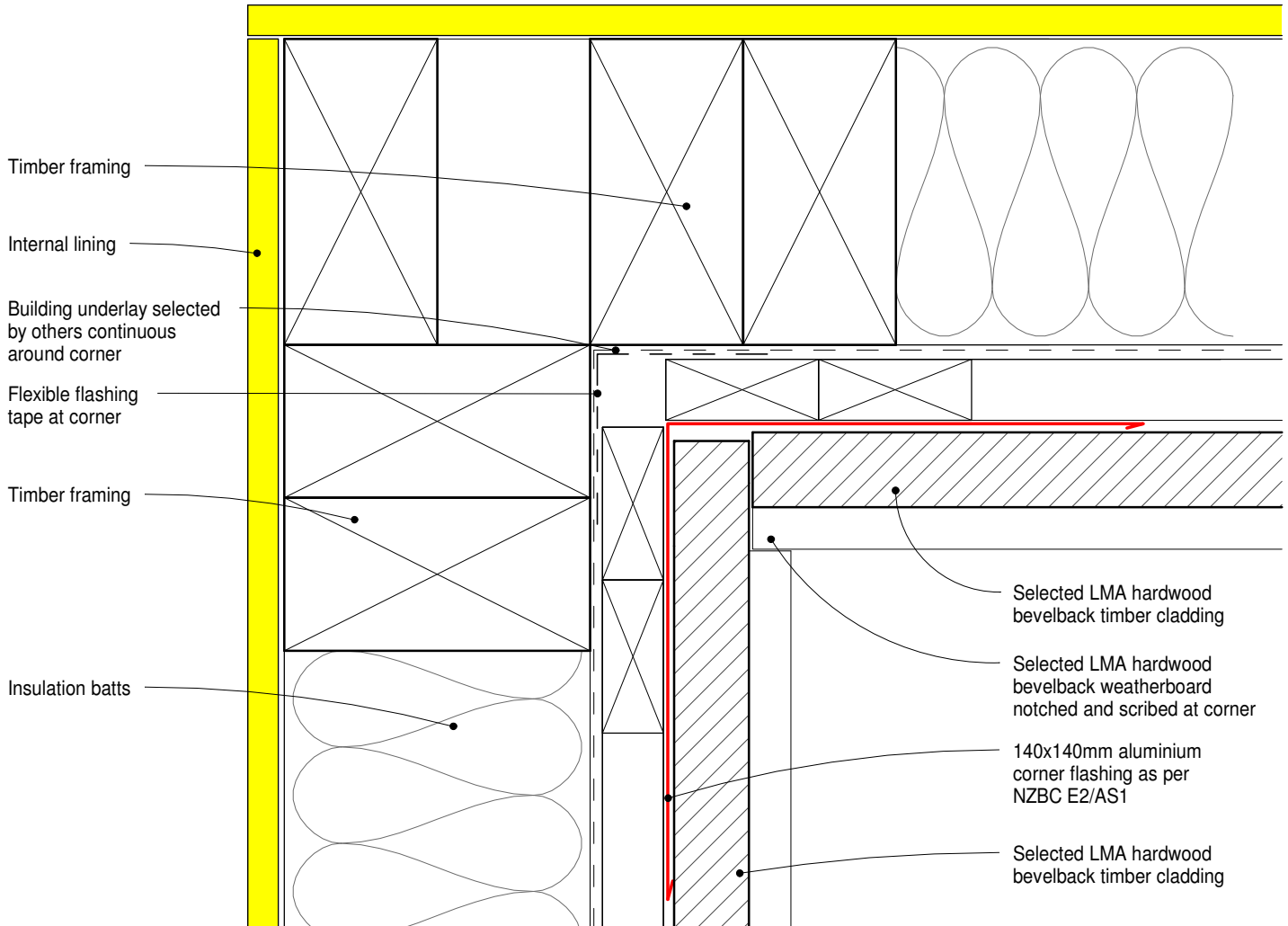

### Contact Details

P: 021 398 800  
E: info@lmatimber.co.nz  
W: www.lmatimber.co.nz  
A: 281 Dyers Road, Bromley, 8062

• TITLE: LMA Bevelback Hardwood Cladding

• DRAWING: Internal Corner\_Scribed

• SCALE: 1 : 2@A4

• DATE:06/03/2020

1. Scope as per Clauses 1.0 and 9.4 E2/AS1
2. Profiles as per NZS 3617 Branz Bulletin 411
3. Fixings as per Table 24 E2/AS1
4. Compatibility of materials as per Tables 20-22 E2/AS1
5. Flashing as per Clause 4.0 E2/AS1
6. Rigid and flexible underlay as per Table 23 and Clauses 9.1.5 to 9.1.7 E2/AS1 or proprietary approved alternative
7. The weatherboard system relies on the joinery meeting the requirements of NZS 4211 for the relevant building wind zone or wind pressure

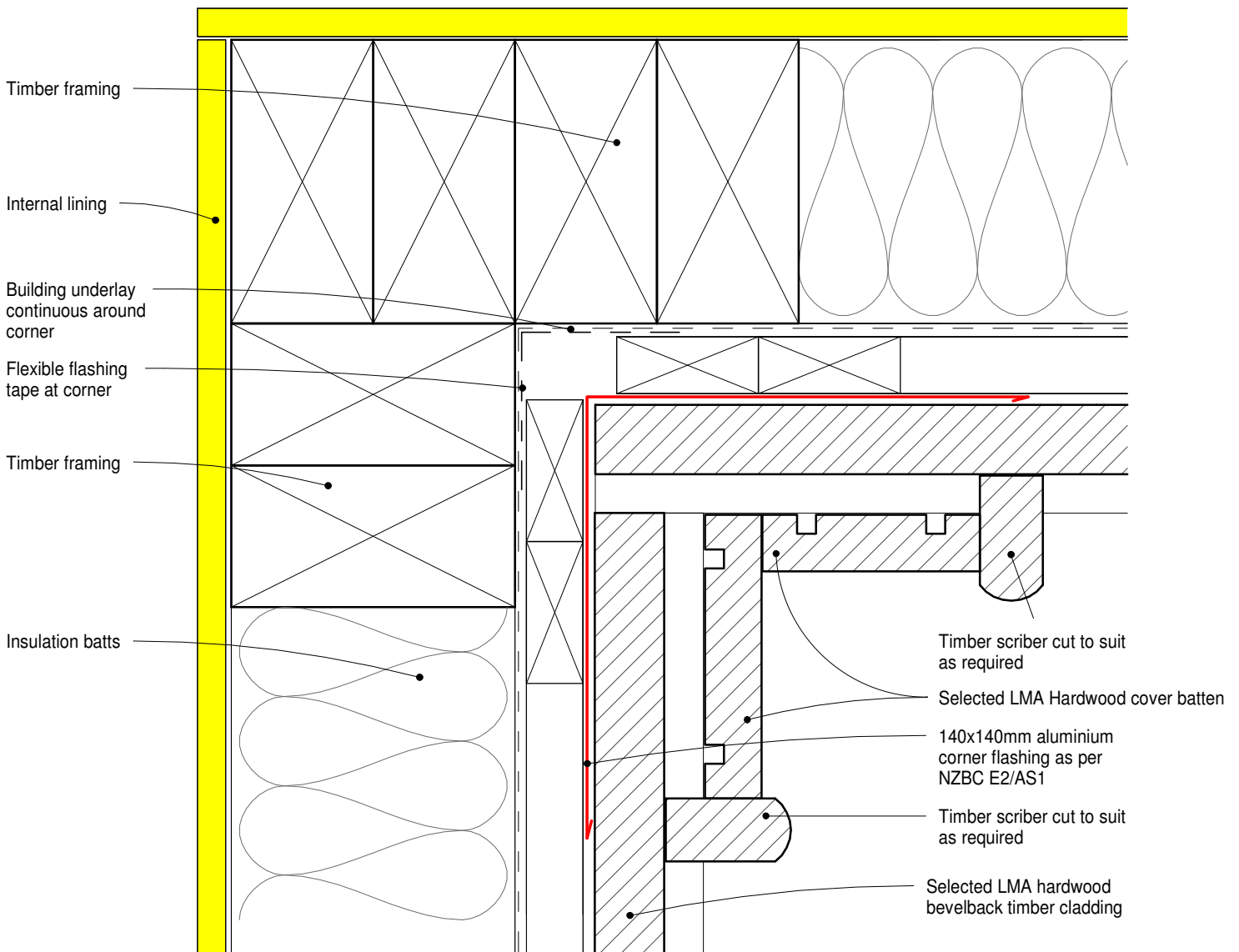

### Contact Details

P: 021 398 800  
 E: info@lmatimber.co.nz  
 W: www.lmatimber.co.nz  
 A: 281 Dyers Road, Bromley, 8062

• TITLE: LMA Bevelback Hardwood Cladding

• DRAWING: Internal Corner\_Boxed

• SCALE: 1 : 2@A4

• DATE:06/03/2020

1. Scope as per Clauses 1.0 and 9.4 E2/AS1
2. Profiles as per NZS 3617 Branz Bulletin 411
3. Fixings as per Table 24 E2/AS1
4. Compatibility of materials as per Tables 20-22 E2/AS1
5. Flashing as per Clause 4.0 E2/AS1
6. Rigid and flexible underlay as per Table 23 and Clauses 9.1.5 to 9.1.7 E2/AS1 or proprietary approved alternative
7. The weatherboard system relies on the joinery meeting the requirements of NZS 4211 for the relevant building wind zone or wind pressure

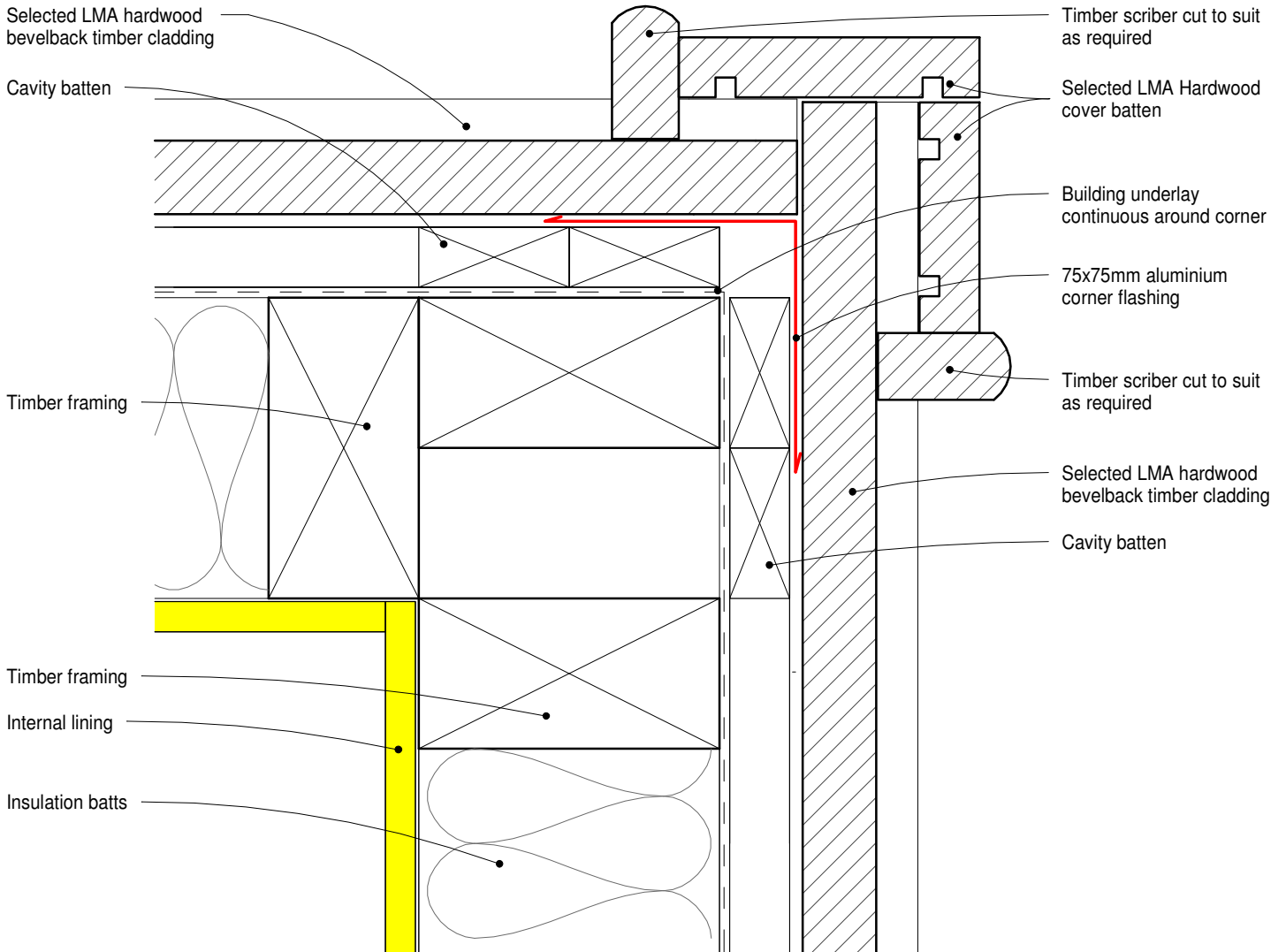

### Contact Details

P: 021 398 800  
E: info@lmatimber.co.nz  
W: www.lmatimber.co.nz  
A: 281 Dyers Road, Bromley, 8062

• TITLE: LMA Bevelback Hardwood Cladding

• DRAWING: External Corner\_Boxed

• SCALE: 1 : 2@A4

• DATE:06/03/2020

1. Scope as per Clauses 1.0 and 9.4 E2/AS1
2. Profiles as per NZS 3617 Branz Bulletin 411
3. Fixings as per Table 24 E2/AS1
4. Compatibility of materials as per Tables 20-22 E2/AS1
5. Flashing as per Clause 4.0 E2/AS1
6. Rigid and flexible underlay as per Table 23 and Clauses 9.1.5 to 9.1.7 E2/AS1 or proprietary approved alternative
7. The weatherboard system relies on the joinery meeting the requirements of NZS 4211 for the relevant building wind zone or wind pressure

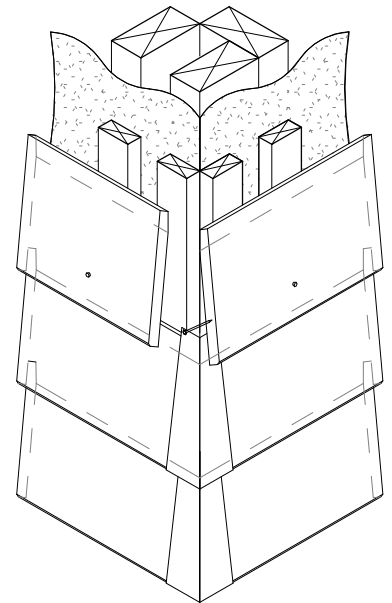
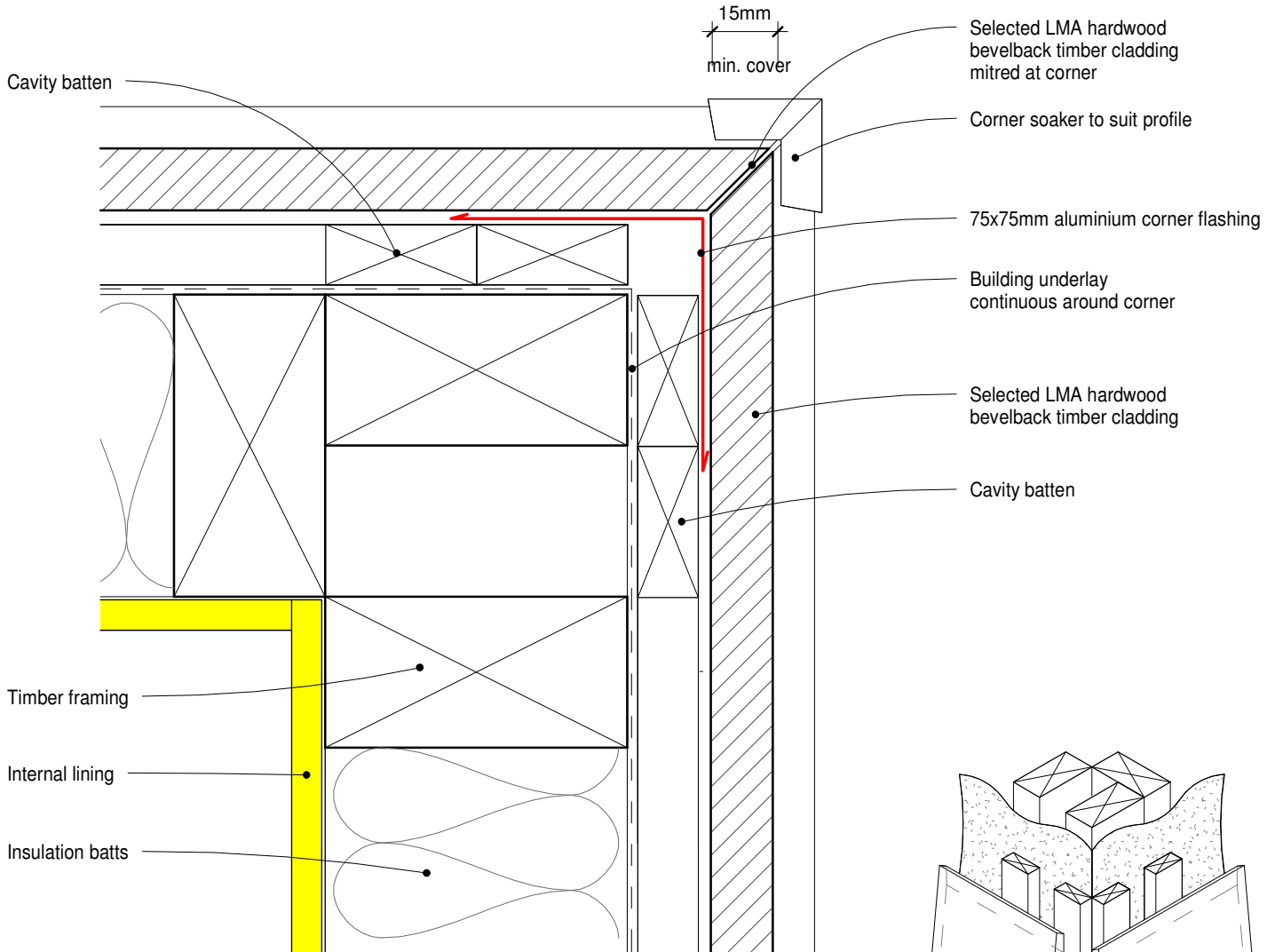

### Contact Details

P: 021 398 800  
E: info@lmatimber.co.nz  
W: www.lmatimber.co.nz  
A: 281 Dyers Road, Bromley, 8062

• TITLE: LMA Bevelback Hardwood Cladding

• DRAWING: External Corner\_Soaker

• SCALE: 1 : 2@A4

• DATE:06/03/2020

1. Scope as per Clauses 1.0 and 9.4 E2/AS1
2. Profiles as per NZS 3617 Branz Bulletin 411
3. Fixings as per Table 24 E2/AS1
4. Compatibility of materials as per Tables 20-22 E2/AS1
5. Flashing as per Clause 4.0 E2/AS1
6. Rigid and flexible underlay as per Table 23 and Clauses 9.1.5 to 9.1.7 E2/AS1 or proprietary approved alternative
7. The weatherboard system relies on the joinery meeting the requirements of NZS 4211 for the relevant building wind zone or wind pressure

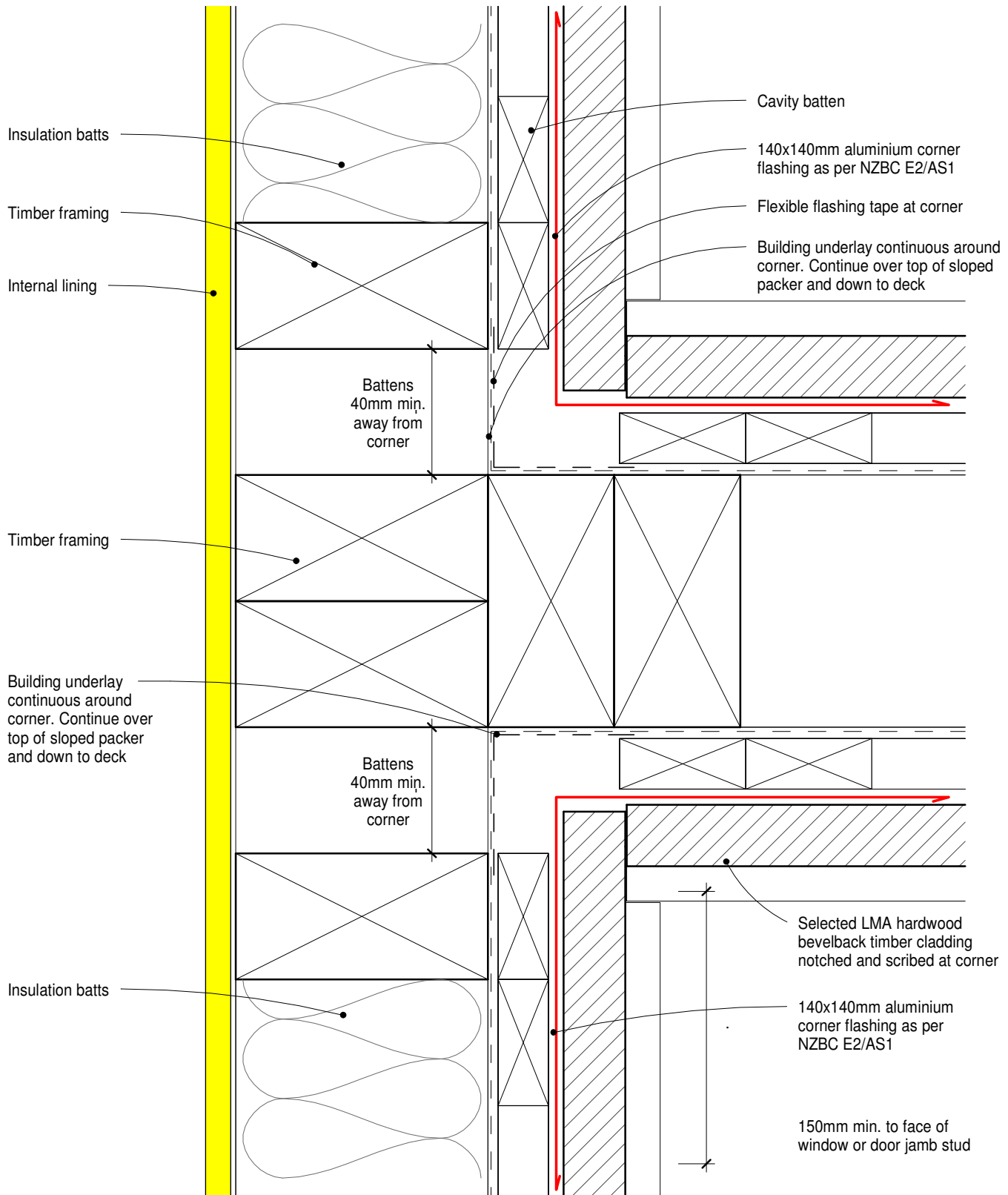

### Contact Details

P: 021 398 800  
E: info@lmatimber.co.nz  
W: www.lmatimber.co.nz  
A: 281 Dyers Road, Bromley, 8062

• TITLE: LMA Bevelback Hardwood Cladding

• DRAWING: Enclosed Deck Balustrade to Wall Junction

• SCALE: 1 : 2@A4

• DATE: 06/03/2020

1. Scope as per Clauses 1.0 and 9.4 E2/AS1
2. Profiles as per NZS 3617 Branz Bulletin 411
3. Fixings as per Table 24 E2/AS1
4. Compatibility of materials as per Tables 20-22 E2/AS1
5. Flashing as per Clause 4.0 E2/AS1
6. Rigid and flexible underlay as per Table 23 and Clauses 9.1.5 to 9.1.7 E2/AS1 or proprietary approved alternative
7. The weatherboard system relies on the joinery meeting the requirements of NZS 4211 for the relevant building wind zone or wind pressure

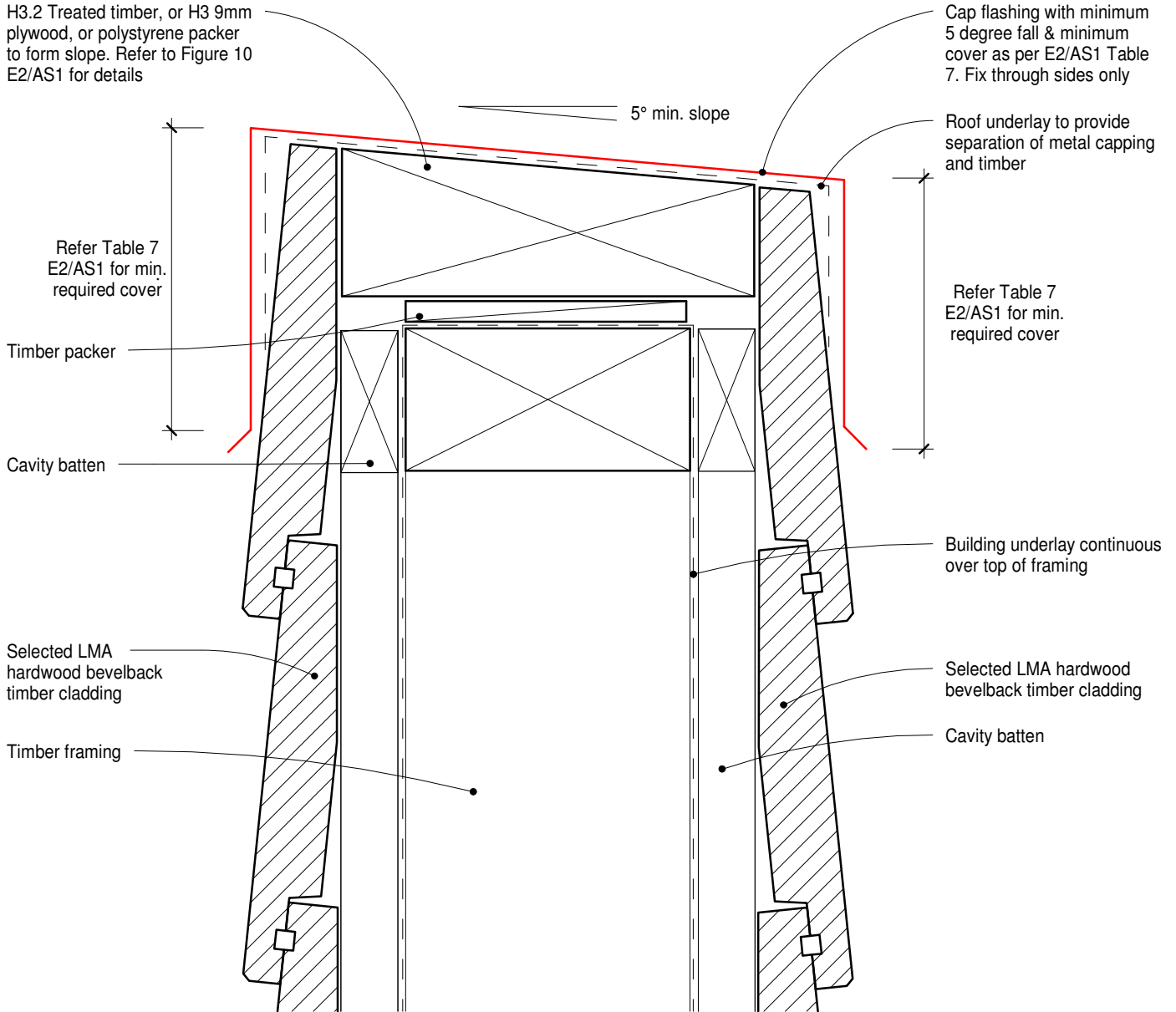

### Contact Details

P: 021 398 800  
E: info@lmatimber.co.nz  
W: www.lmatimber.co.nz  
A: 281 Dyers Road, Bromley, 8062

• TITLE: LMA Bevelback Hardwood Cladding

• DRAWING: Parapet Detail

• SCALE: 1 : 2@A4

• DATE: 06/03/2020

1. Scope as per Clauses 1.0 and 9.4 E2/AS1
2. Profiles as per NZS 3617 Branz Bulletin 411
3. Fixings as per Table 24 E2/AS1
4. Compatibility of materials as per Tables 20-22 E2/AS1
5. Flashing as per Clause 4.0 E2/AS1
6. Rigid and flexible underlay as per Table 23 and Clauses 9.1.5 to 9.1.7 E2/AS1 or proprietary approved alternative
7. The weatherboard system relies on the joinery meeting the requirements of NZS 4211 for the relevant building wind zone or wind pressure

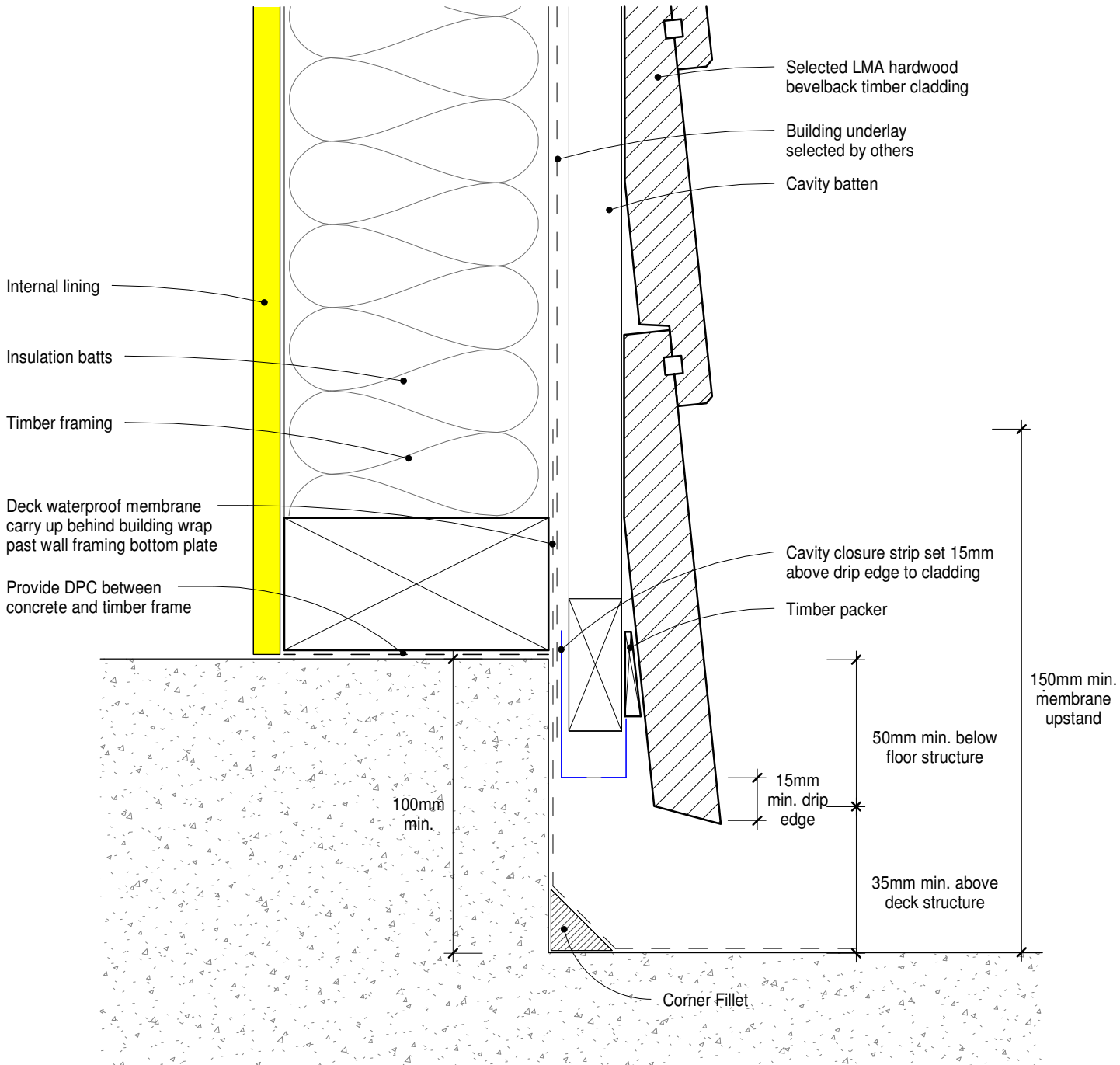

### Contact Details

P: 021 398 800  
E: info@lmatimber.co.nz  
W: www.lmatimber.co.nz  
A: 281 Dyers Road, Bromley, 8062

• TITLE: LMA Bevelback Hardwood Cladding

• DRAWING: Cavity at Enclosed Deck

• SCALE: 1 : 2@A4

• DATE: 06/03/2020

1. Scope as per Clauses 1.0 and 9.4 E2/AS1
2. Profiles as per NZS 3617 Branz Bulletin 411
3. Fixings as per Table 24 E2/AS1
4. Compatibility of materials as per Tables 20-22 E2/AS1
5. Flashing as per Clause 4.0 E2/AS1
6. Rigid and flexible underlay as per Table 23 and Clauses 9.1.5 to 9.1.7 E2/AS1 or proprietary approved alternative
7. The weatherboard system relies on the joinery meeting the requirements of NZS 4211 for the relevant building wind zone or wind pressure

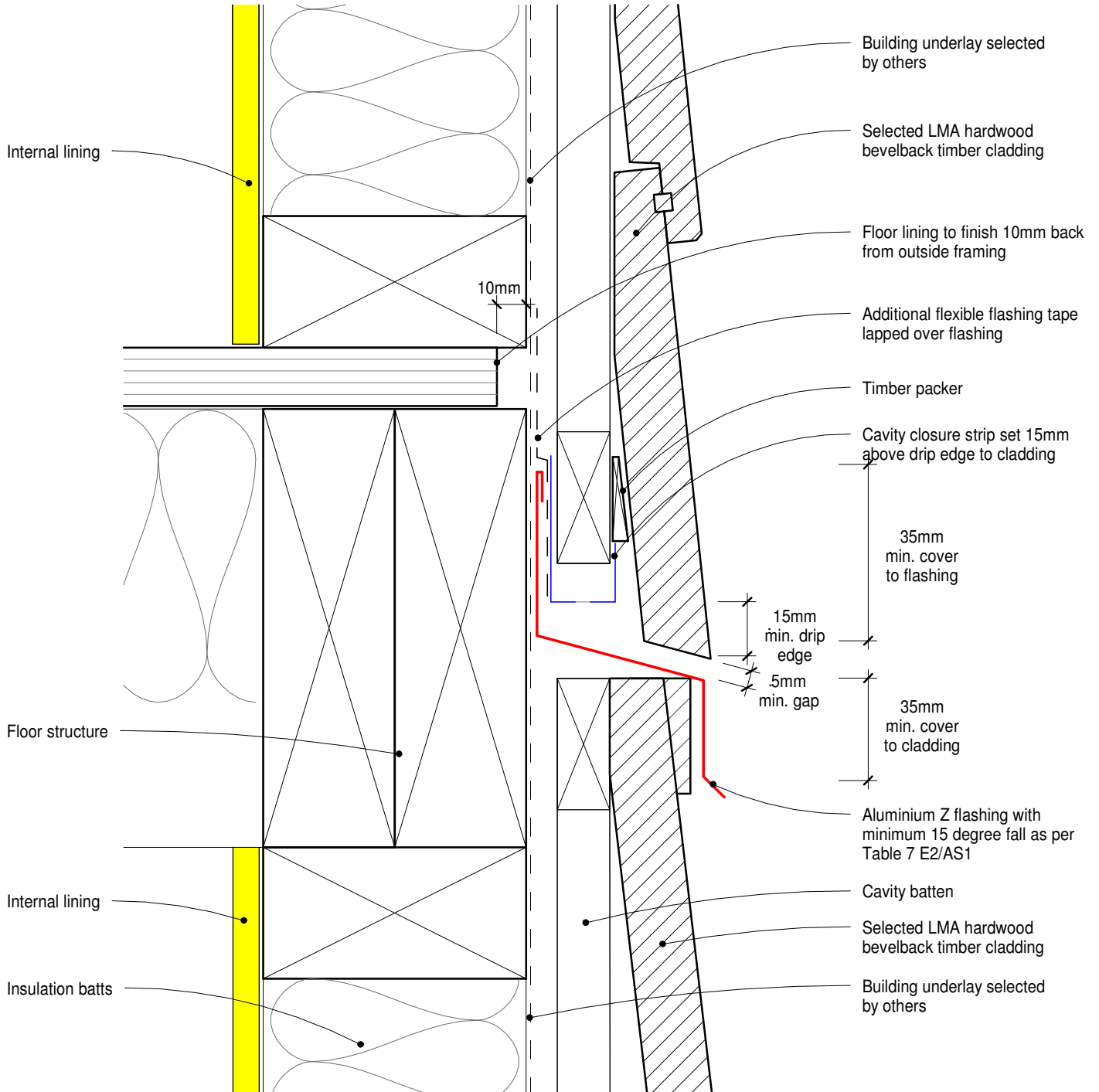

### Contact Details

P: 021 398 800  
E: info@lmatimber.co.nz  
W: www.lmatimber.co.nz  
A: 281 Dyers Road, Bromley, 8062

• TITLE: LMA Bevelback Hardwood Cladding

• DRAWING: Drained Inter-Storey Joint

• SCALE: 1 : 2@A4

• DATE:06/03/2020

1. Scope as per Clauses 1.0 and 9.4 E2/AS1
2. Profiles as per NZS 3617 Branz Bulletin 411
3. Fixings as per Table 24 E2/AS1
4. Compatibility of materials as per Tables 20-22 E2/AS1
5. Flashing as per Clause 4.0 E2/AS1
6. Rigid and flexible underlay as per Table 23 and Clauses 9.1.5 to 9.1.7 E2/AS1 or proprietary approved alternative
7. The weatherboard system relies on the joinery meeting the requirements of NZS 4211 for the relevant building wind zone or wind pressure

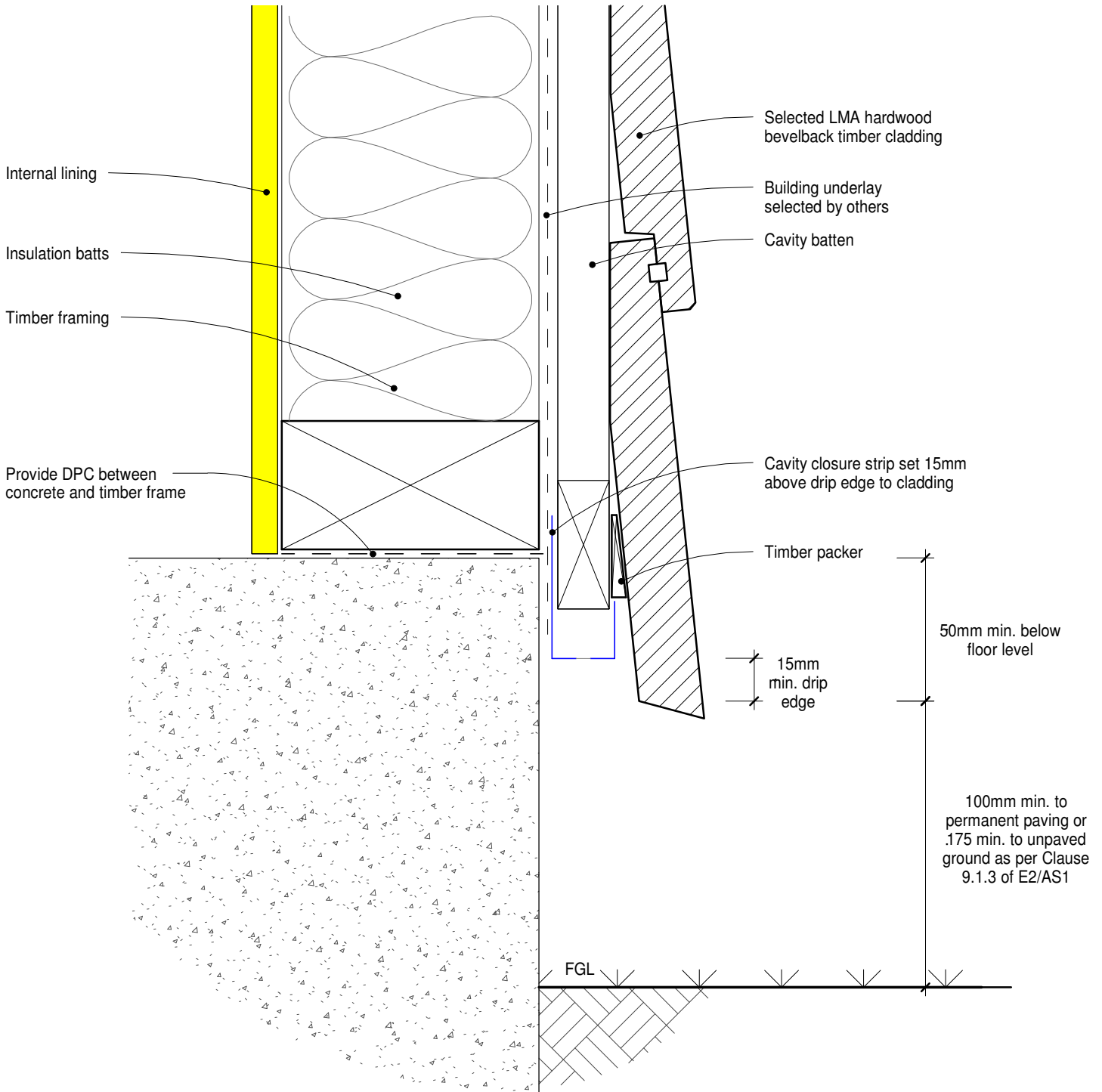

### Contact Details

1. Scope as per Clauses 1.0 and 9.4 E2/AS1
2. Profiles as per NZS 3617 Branz Bulletin 411
3. Fixings as per Table 24 E2/AS1
4. Compatibility of materials as per Tables 20-22 E2/AS1
5. Flashing as per Clause 4.0 E2/AS1
6. Rigid and flexible underlay as per Table 23 and Clauses 9.1.5 to 9.1.7 E2/AS1 or proprietary approved alternative
7. The weatherboard system relies on the joinery meeting the requirements of NZS 4211 for the relevant building wind zone or wind pressure

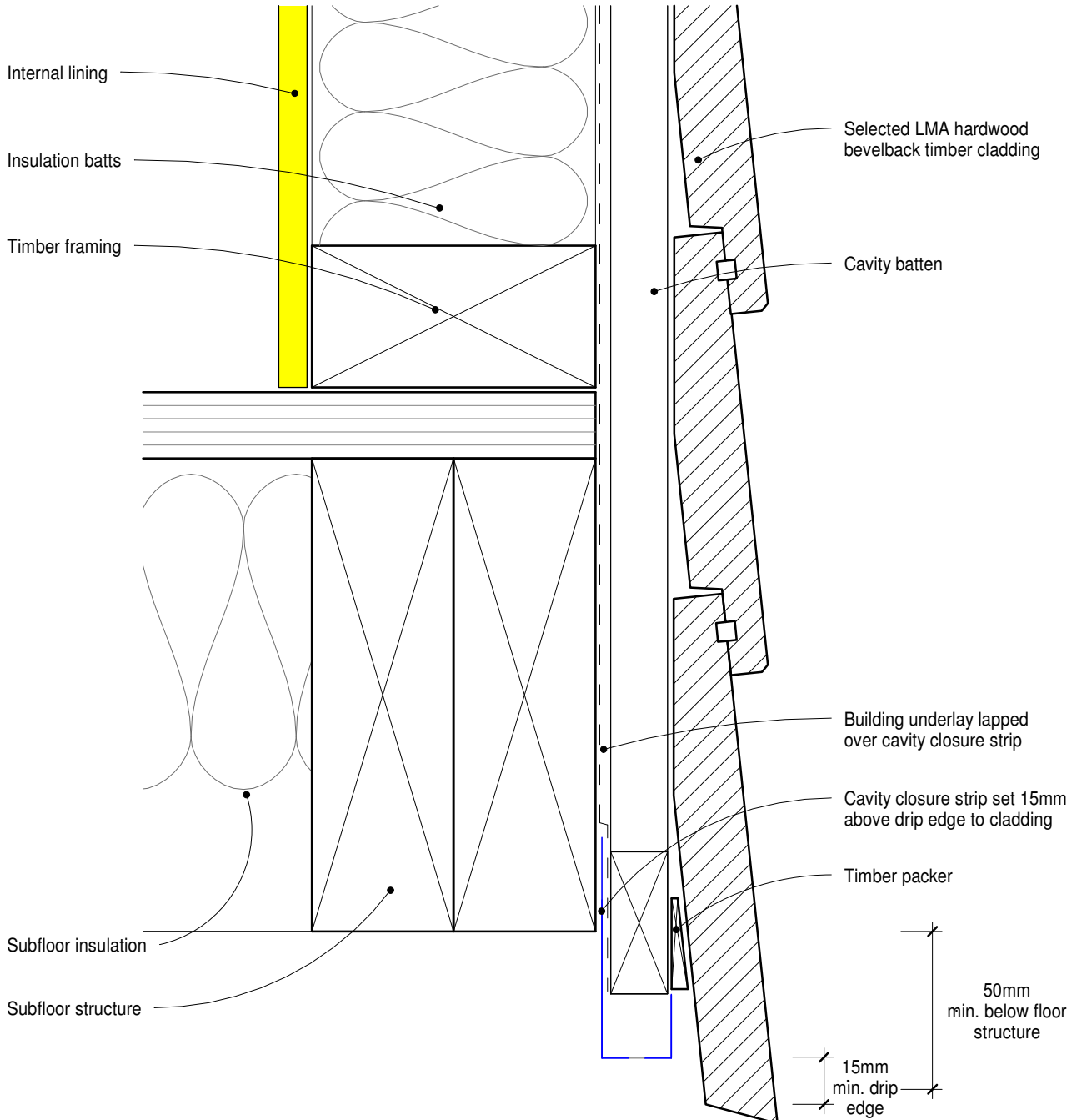

### Contact Details

P: 021 398 800  
E: info@lmatimber.co.nz  
W: www.lmatimber.co.nz  
A: 281 Dyers Road, Bromley, 8062

• TITLE: LMA Bevelback Hardwood Cladding

• DRAWING: Base of Wall\_Timber

• SCALE: 1 : 2@A4

• DATE:06/03/2020

1. Scope as per Clauses 1.0 and 9.4 E2/AS1
2. Profiles as per NZS 3617 Branz Bulletin 411
3. Fixings as per Table 24 E2/AS1
4. Compatibility of materials as per Tables 20-22 E2/AS1
5. Flashing as per Clause 4.0 E2/AS1
6. Rigid and flexible underlay as per Table 23 and Clauses 9.1.5 to 9.1.7 E2/AS1 or proprietary approved alternative
7. The weatherboard system relies on the joinery meeting the requirements of NZS 4211 for the relevant building wind zone or wind pressure

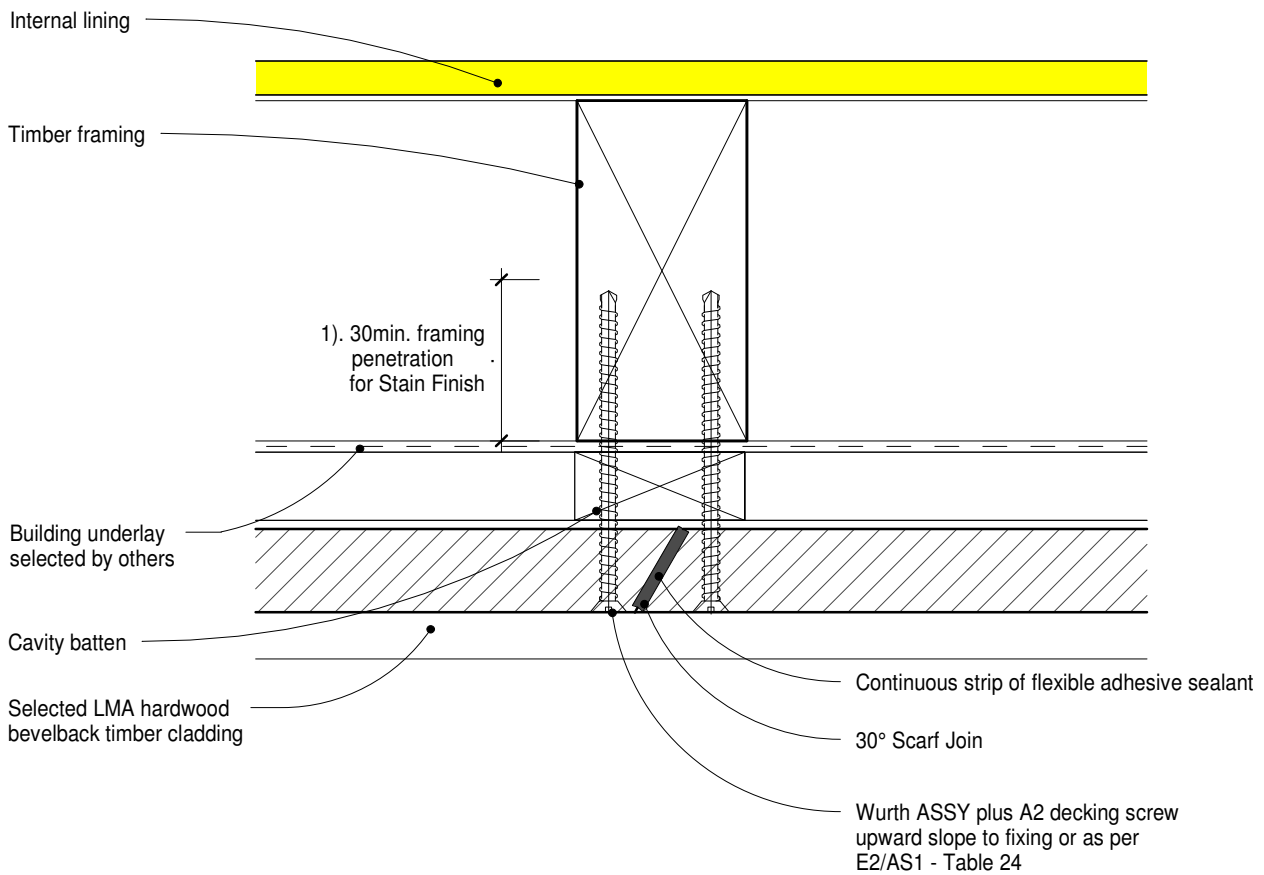

**NOTE:**

Cut ends of scarf joint must be double coated with oil or stain.

**Contact Details**

P: 021 398 800  
E: info@lmatimber.co.nz  
W: www.lmatimber.co.nz  
A: 281 Dyers Road, Bromley, 8062

• TITLE: LMA Bevelback Hardwood Cladding

• DRAWING: Scarf Join Stain Finish

• SCALE: 1 : 2@A4

• DATE:06/03/2020

1. Scope as per Clauses 1.0 and 9.4 E2/AS1
2. Profiles as per NZS 3617 Branz Bulletin 411
3. Fixings as per Table 24 E2/AS1
4. Compatibility of materials as per Tables 20-22 E2/AS1
5. Flashing as per Clause 4.0 E2/AS1
6. Rigid and flexible underlay as per Table 23 and Clauses 9.1.5 to 9.1.7 E2/AS1 or proprietary approved alternative
7. The weatherboard system relies on the joinery meeting the requirements of NZS 4211 for the relevant building wind zone or wind pressure

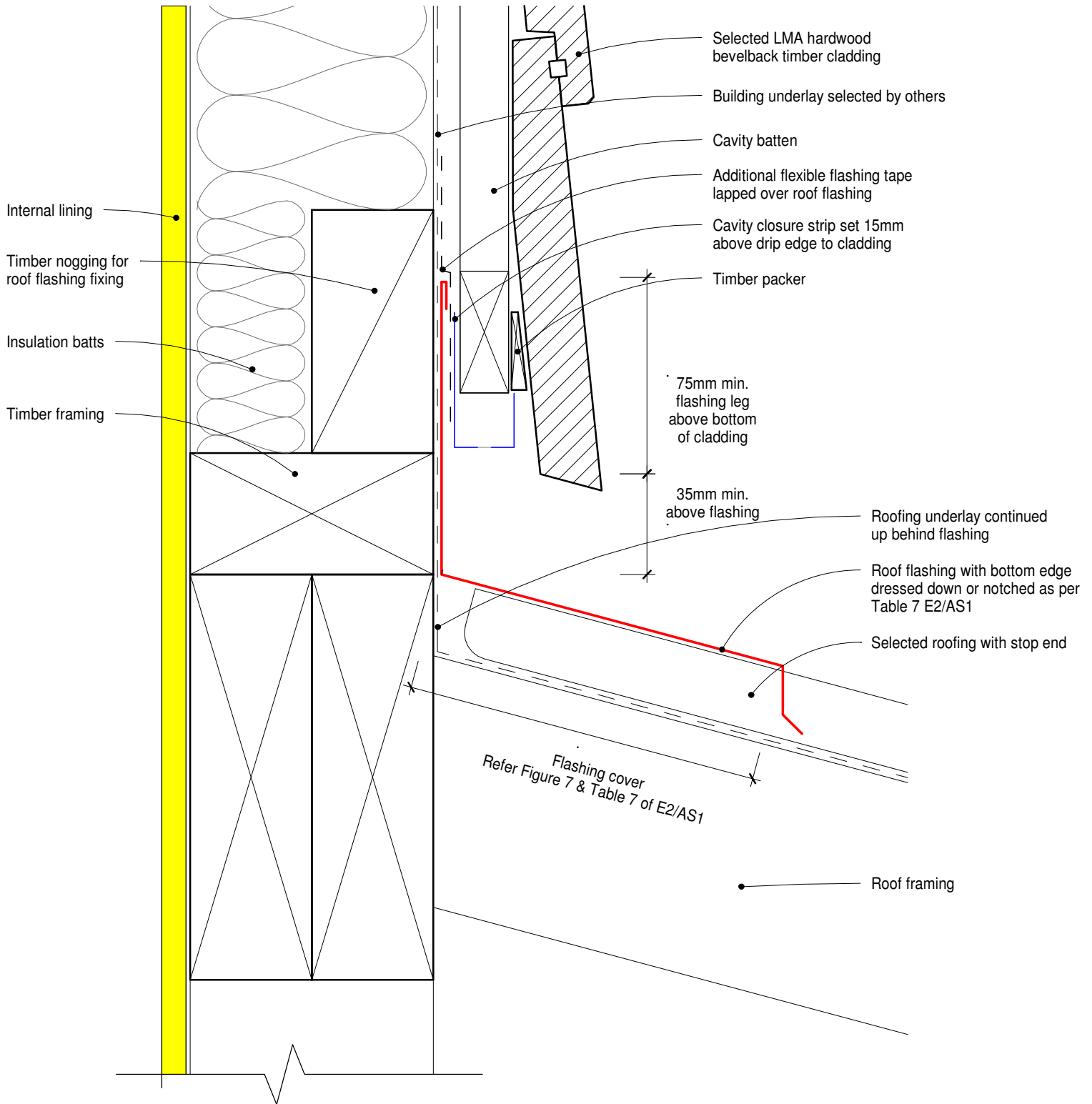

### Contact Details

P: 021 398 800  
E: info@lmatimber.co.nz  
W: www.lmatimber.co.nz  
A: 281 Dyers Road, Bromley, 8062

• TITLE: LMA Bevelback Hardwood Cladding

• DRAWING: Roof/Wall Junction

• SCALE: 1 : 2@A4

• DATE:06/03/2020

1. Scope as per Clauses 1.0 and 9.4 E2/AS1
2. Profiles as per NZS 3617 Branz Bulletin 411
3. Fixings as per Table 24 E2/AS1
4. Compatibility of materials as per Tables 20-22 E2/AS1
5. Flashing as per Clause 4.0 E2/AS1
6. Rigid and flexible underlay as per Table 23 and Clauses 9.1.5 to 9.1.7 E2/AS1 or proprietary approved alternative
7. The weatherboard system relies on the joinery meeting the requirements of NZS 4211 for the relevant building wind zone or wind pressure

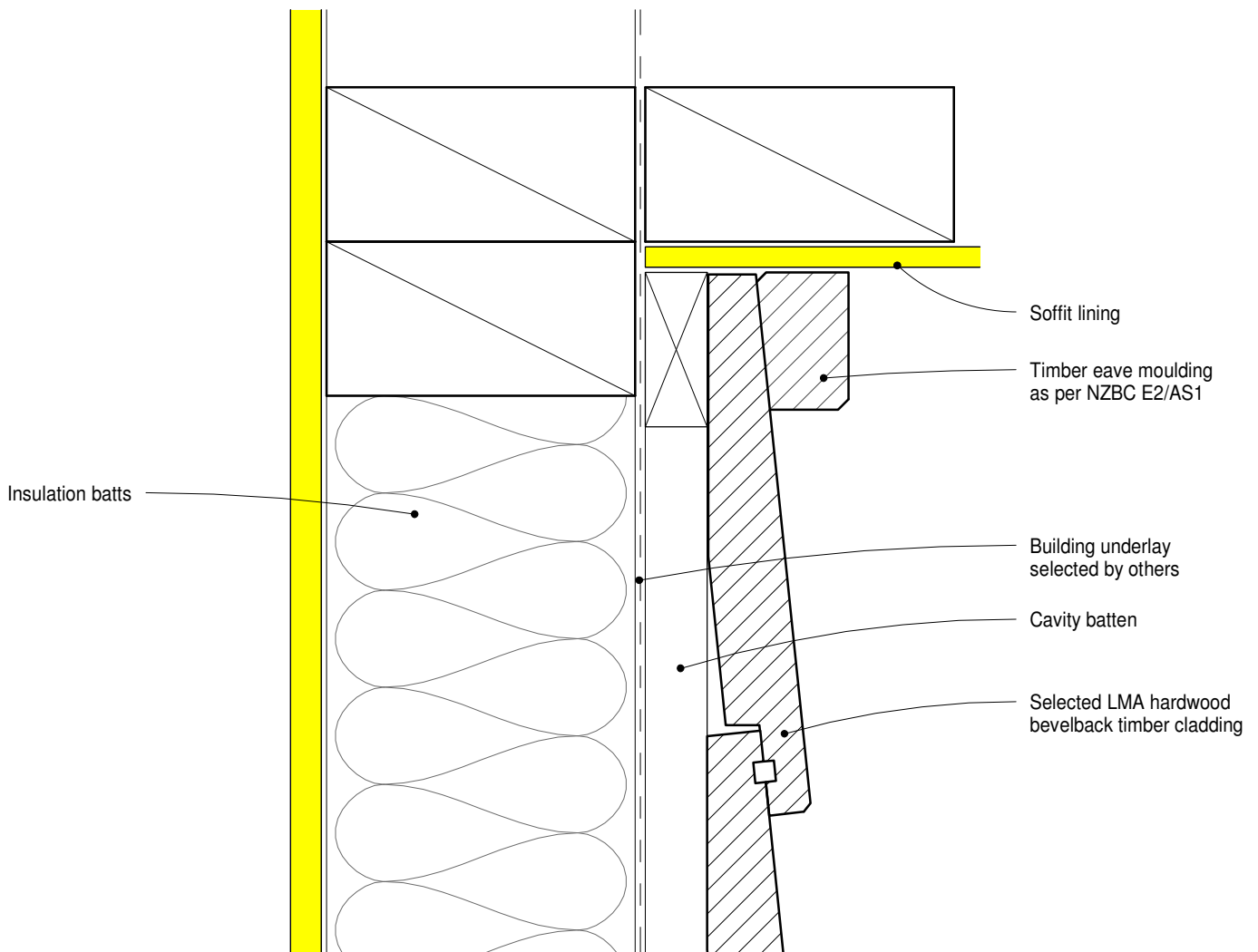

### Contact Details

P: 021 398 800  
E: info@lmatimber.co.nz  
W: www.lmatimber.co.nz  
A: 281 Dyers Road, Bromley, 8062

• TITLE: LMA Bevelback Hardwood Cladding

• DRAWING: Soffit Detail\_Overhang

• SCALE: 1 : 2@A4

• DATE:06/03/2020

1. Scope as per Clauses 1.0 and 9.4 E2/AS1
2. Profiles as per NZS 3617 Branz Bulletin 411
3. Fixings as per Table 24 E2/AS1
4. Compatibility of materials as per Tables 20-22 E2/AS1
5. Flashing as per Clause 4.0 E2/AS1
6. Rigid and flexible underlay as per Table 23 and Clauses 9.1.5 to 9.1.7 E2/AS1 or proprietary approved alternative
7. The weatherboard system relies on the joinery meeting the requirements of NZS 4211 for the relevant building wind zone or wind pressure

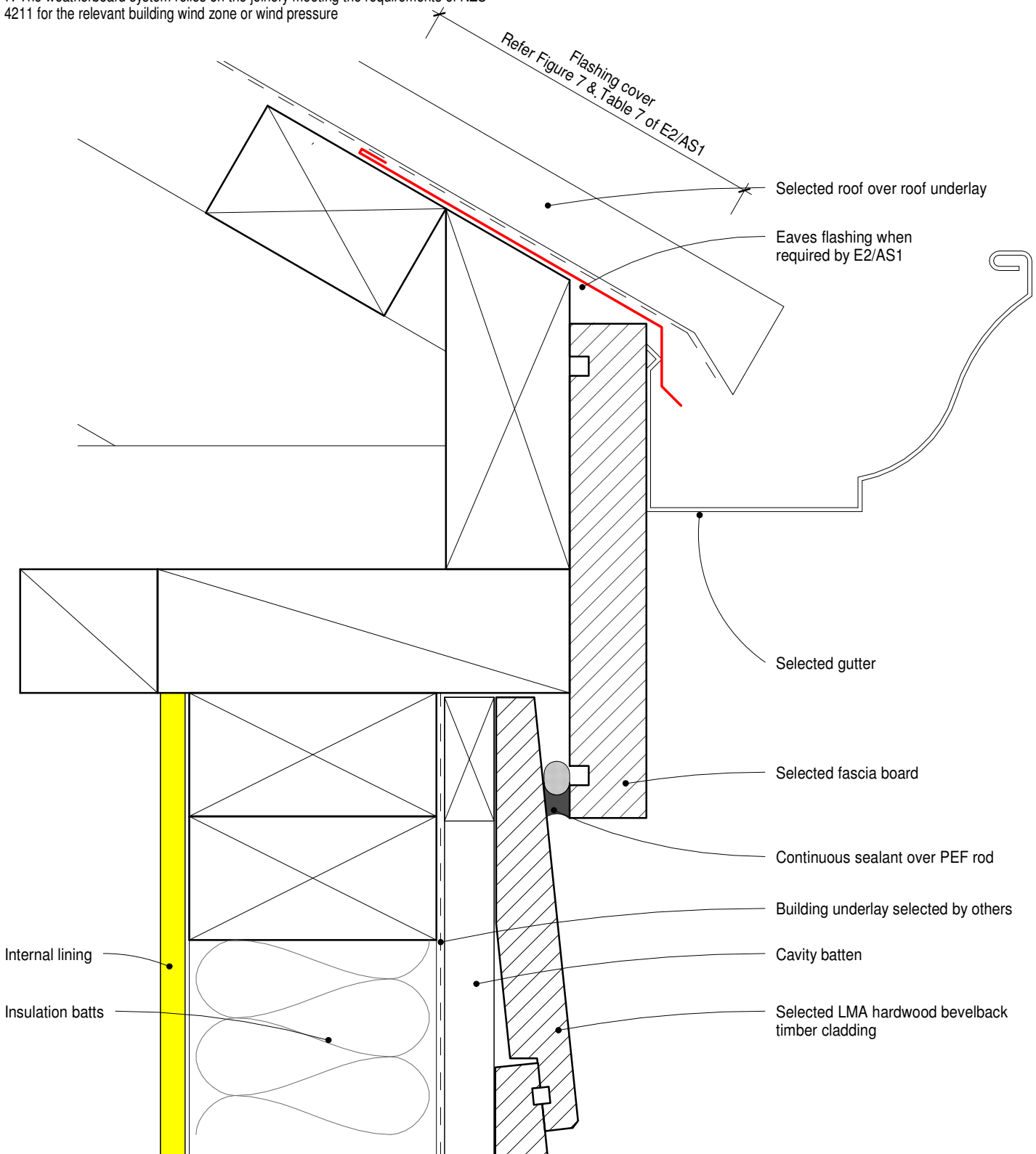

### Contact Details

P: 021 398 800  
 E: info@lmatimber.co.nz  
 W: www.lmatimber.co.nz  
 A: 281 Dyers Road, Bromley, 8062

• TITLE: LMA Bevelback Hardwood Cladding

• DRAWING: Eaves Detail\_No Overhang

• SCALE: 1 : 2@A4

• DATE: 06/03/2020

1. Scope as per Clauses 1.0 and 9.4 E2/AS1
2. Profiles as per NZS 3617 Branz Bulletin 411
3. Fixings as per Table 24 E2/AS1
4. Compatibility of materials as per Tables 20-22 E2/AS1
5. Flashing as per Clause 4.0 E2/AS1
6. Rigid and flexible underlay as per Table 23 and Clauses 9.1.5 to 9.1.7 E2/AS1 or proprietary approved alternative
7. The weatherboard system relies on the joinery meeting the requirements of NZS 4211 for the relevant building wind zone or wind pressure

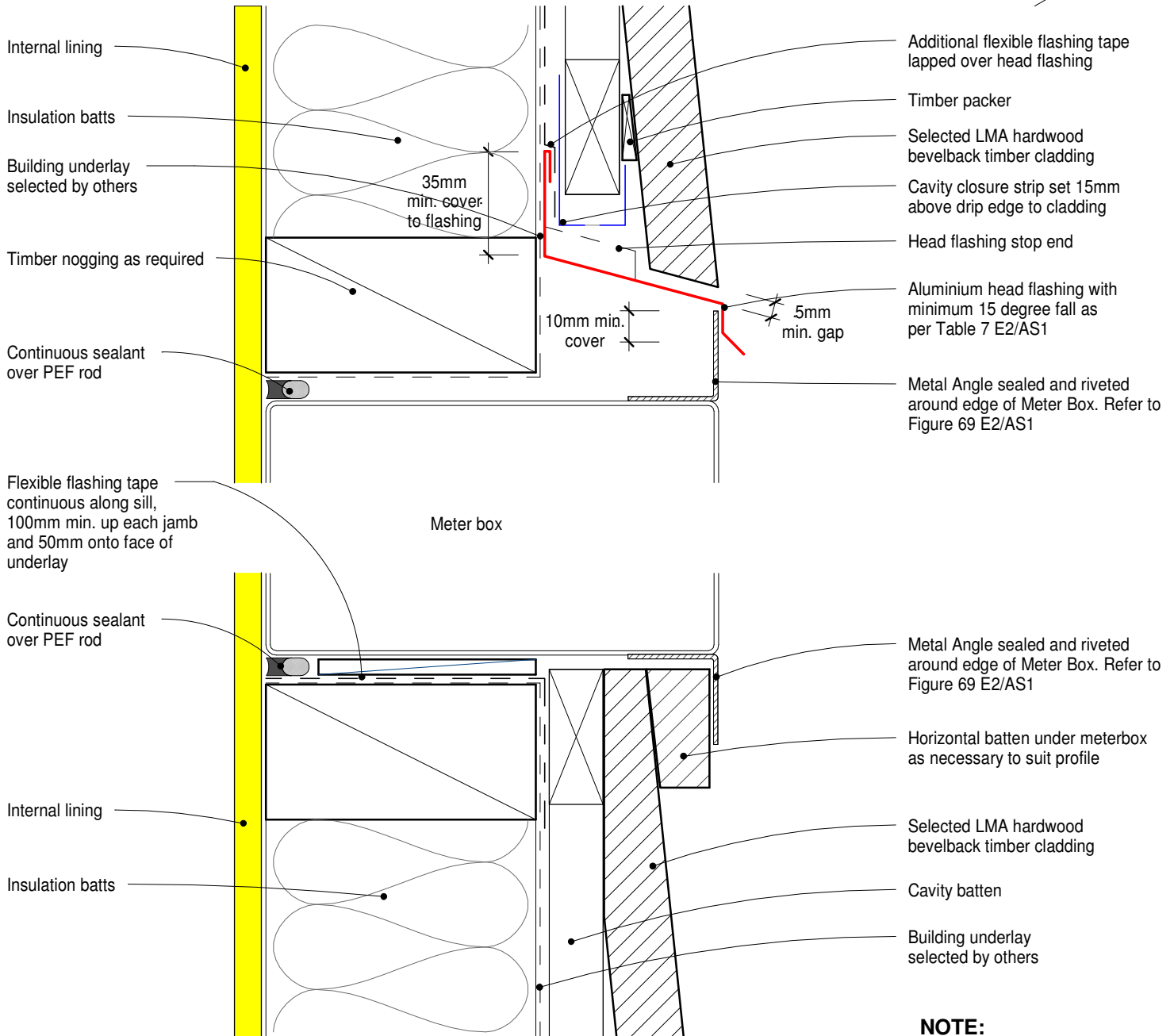
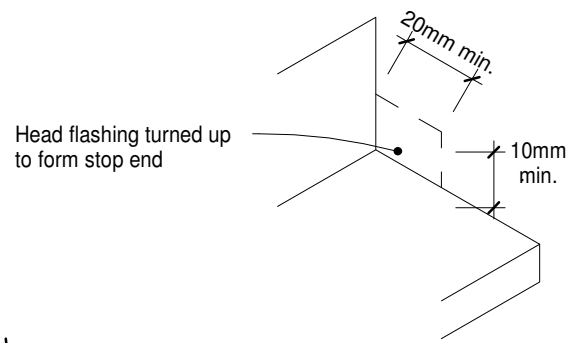

**NOTE:**  
Jamb detail similar to sill

### Contact Details

P: 021 398 800  
E: info@lmatimber.co.nz  
W: www.lmatimber.co.nz  
A: 281 Dyers Road, Bromley, 8062

• TITLE: LMA Bevelback Hardwood Cladding

• DRAWING: Meter Box Detail

• SCALE: 1 : 2@A4

• DATE: 06/03/2020

1. Scope as per Clauses 1.0 and 9.4 E2/AS1
2. Profiles as per NZS 3617 Branz Bulletin 411
3. Fixings as per Table 24 E2/AS1
4. Compatibility of materials as per Tables 20-22 E2/AS1
5. Flashing as per Clause 4.0 E2/AS1
6. Rigid and flexible underlay as per Table 23 and Clauses 9.1.5 to 9.1.7 E2/AS1 or proprietary approved alternative
7. The weatherboard system relies on the joinery meeting the requirements of NZS 4211 for the relevant building wind zone or wind pressure

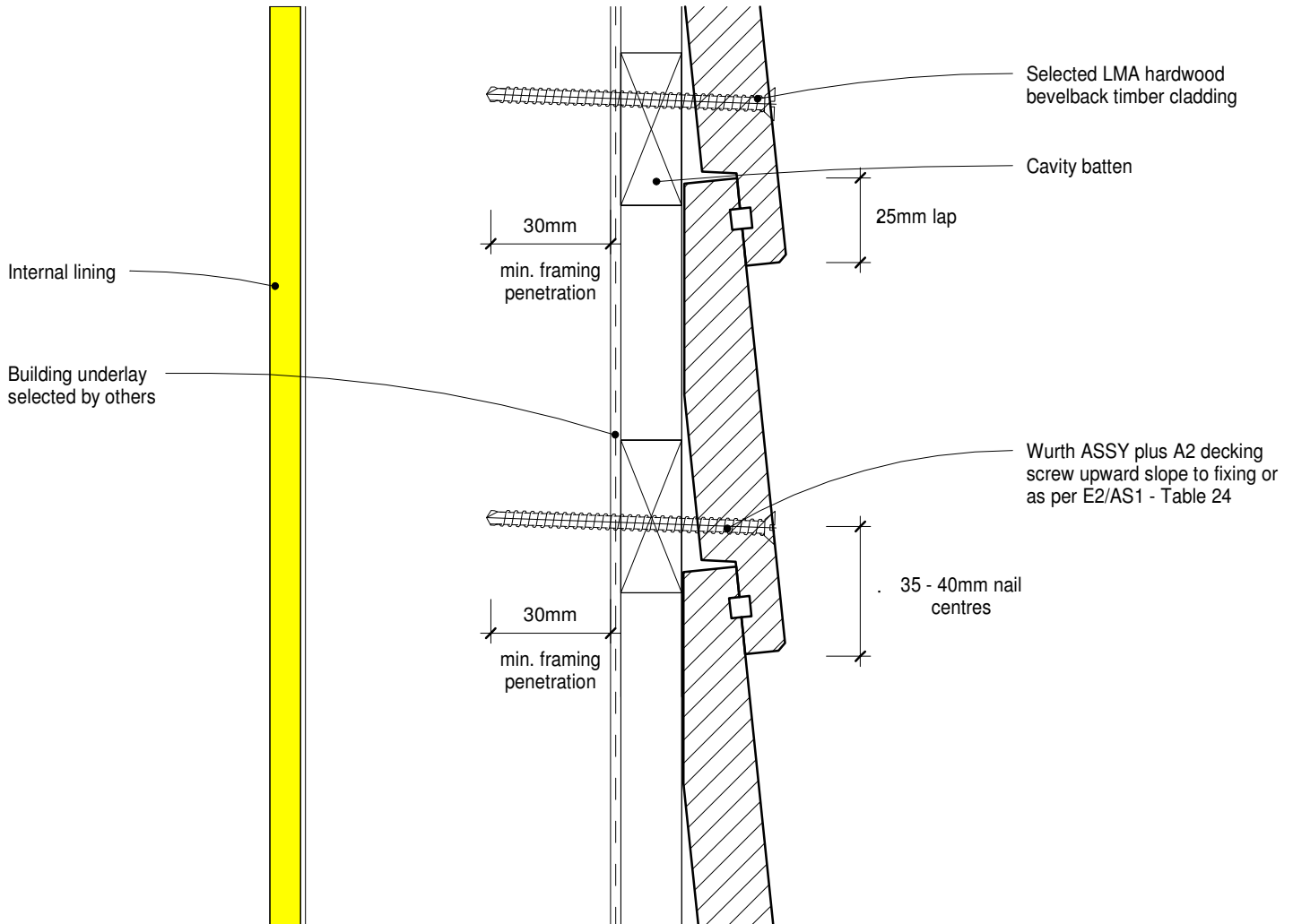

### Contact Details

P: 021 398 800  
 E: info@lmatimber.co.nz  
 W: www.lmatimber.co.nz  
 A: 281 Dyers Road, Bromley, 8062

• TITLE: LMA Bevelback Hardwood Cladding

• DRAWING: General Nail fixing\_ Stain Finish

• SCALE: 1 : 2@A4

• DATE: 06/03/2020

1. Scope as per Clauses 1.0 and 9.4 E2/AS1
2. Profiles as per NZS 3617 Branz Bulletin 411
3. Fixings as per Table 24 E2/AS1
4. Compatibility of materials as per Tables 20-22 E2/AS1
5. Flashing as per Clause 4.0 E2/AS1
6. Rigid and flexible underlay as per Table 23 and Clauses 9.1.5 to 9.1.7 E2/AS1 or proprietary approved alternative
7. The weatherboard system relies on the joinery meeting the requirements of NZS 4211 for the relevant building wind zone or wind pressure

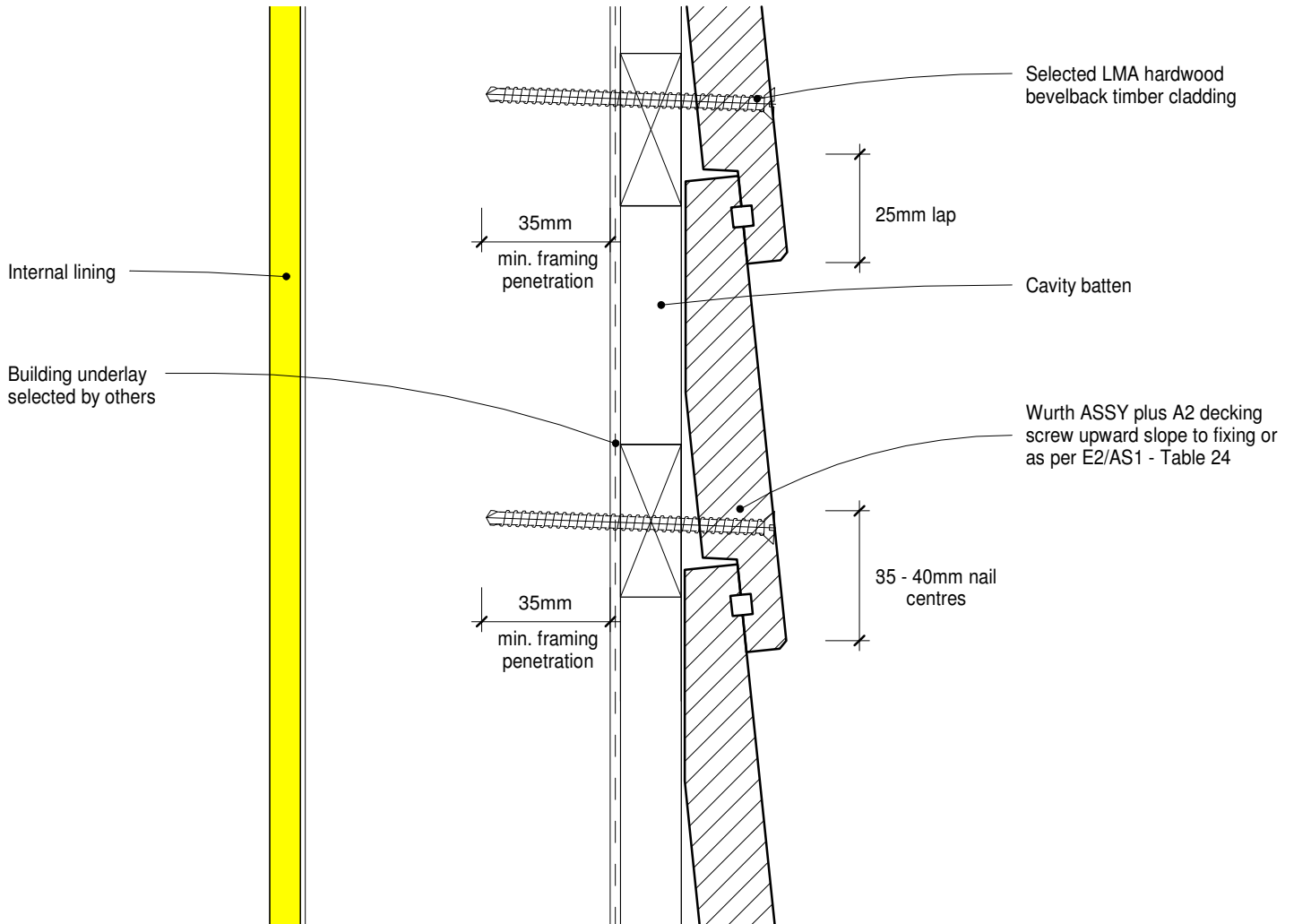

### Contact Details

P: 021 398 800  
E: info@lmatimber.co.nz  
W: www.lmatimber.co.nz  
A: 281 Dyers Road, Bromley, 8062

• TITLE: LMA Bevelback Hardwood Cladding

• DRAWING: General Nail Fixing\_Paint Finish

• SCALE: 1 : 2@A4

• DATE:06/03/2020

1. Scope as per Clauses 1.0 and 9.4 E2/AS1
2. Profiles as per NZS 3617 Branz Bulletin 411
3. Fixings as per Table 24 E2/AS1
4. Compatibility of materials as per Tables 20-22 E2/AS1
5. Flashing as per Clause 4.0 E2/AS1
6. Rigid and flexible underlay as per Table 23 and Clauses 9.1.5 to 9.1.7 E2/AS1 or proprietary approved alternative
7. The weatherboard system relies on the joinery meeting the requirements of NZS 4211 for the relevant building wind zone or wind pressure

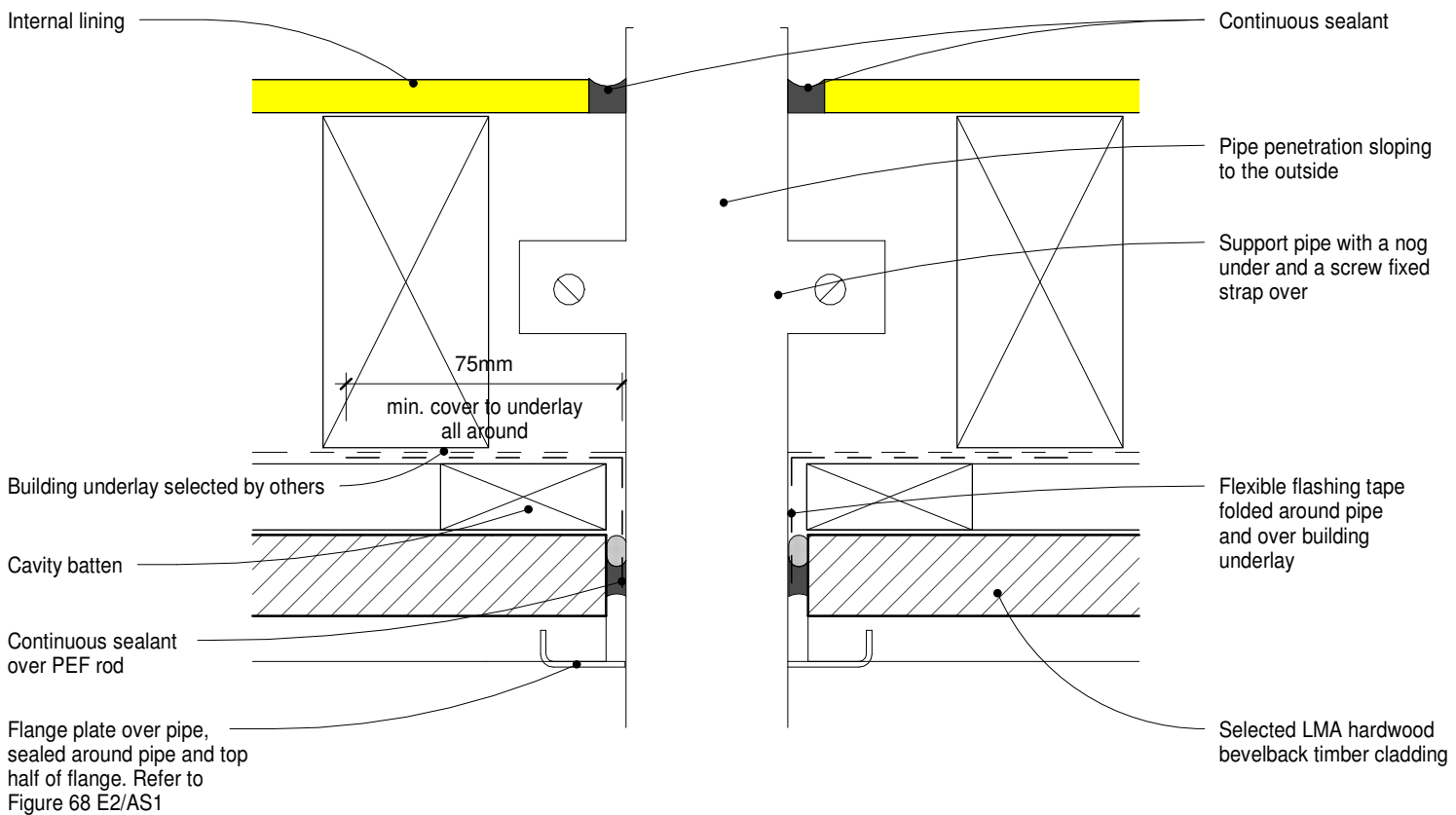

### Contact Details

P: 021 398 800  
E: info@lmatimber.co.nz  
W: www.lmatimber.co.nz  
A: 281 Dyers Road, Bromley, 8062

• TITLE: LMA Bevelback Hardwood Cladding

• DRAWING: Pipe Penetration Plan Detail

• SCALE: 1 : 2@A4

• DATE: 06/03/2020

1. Scope as per Clauses 1.0 and 9.4 E2/AS1
2. Profiles as per NZS 3617 Branz Bulletin 411
3. Fixings as per Table 24 E2/AS1
4. Compatibility of materials as per Tables 20-22 E2/AS1
5. Flashing as per Clause 4.0 E2/AS1
6. Rigid and flexible underlay as per Table 23 and Clauses 9.1.5 to 9.1.7 E2/AS1 or proprietary approved alternative
7. The weatherboard system relies on the joinery meeting the requirements of NZS 4211 for the relevant building wind zone or wind pressure

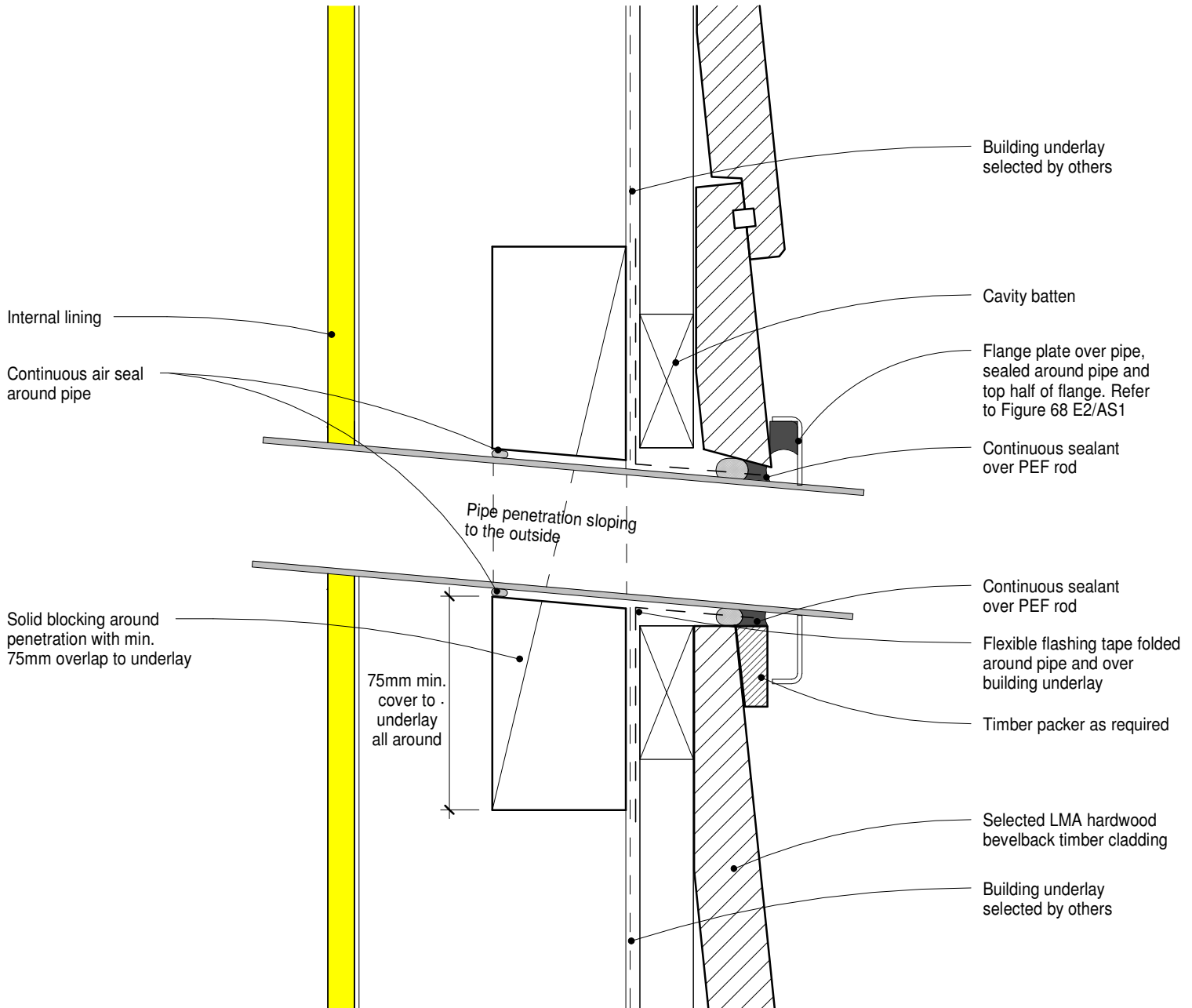

### Contact Details

P: 021 398 800  
E: info@lmatimber.co.nz  
W: www.lmatimber.co.nz  
A: 281 Dyers Road, Bromley, 8062

• TITLE: LMA Bevelback Hardwood Cladding

• DRAWING: Pipe Penetration Detail

• SCALE: 1 : 2@A4

• DATE: 06/03/2020

1. Scope as per Clauses 1.0 and 9.4 E2/AS1
2. Profiles as per NZS 3617 Branz Bulletin 411
3. Fixings as per Table 24 E2/AS1
4. Compatibility of materials as per Tables 20-22 E2/AS1
5. Flashing as per Clause 4.0 E2/AS1
6. Rigid and flexible underlay as per Table 23 and Clauses 9.1.5 to 9.1.7 E2/AS1 or proprietary approved alternative
7. The weatherboard system relies on the joinery meeting the requirements of NZS 4211 for the relevant building wind zone or wind pressure

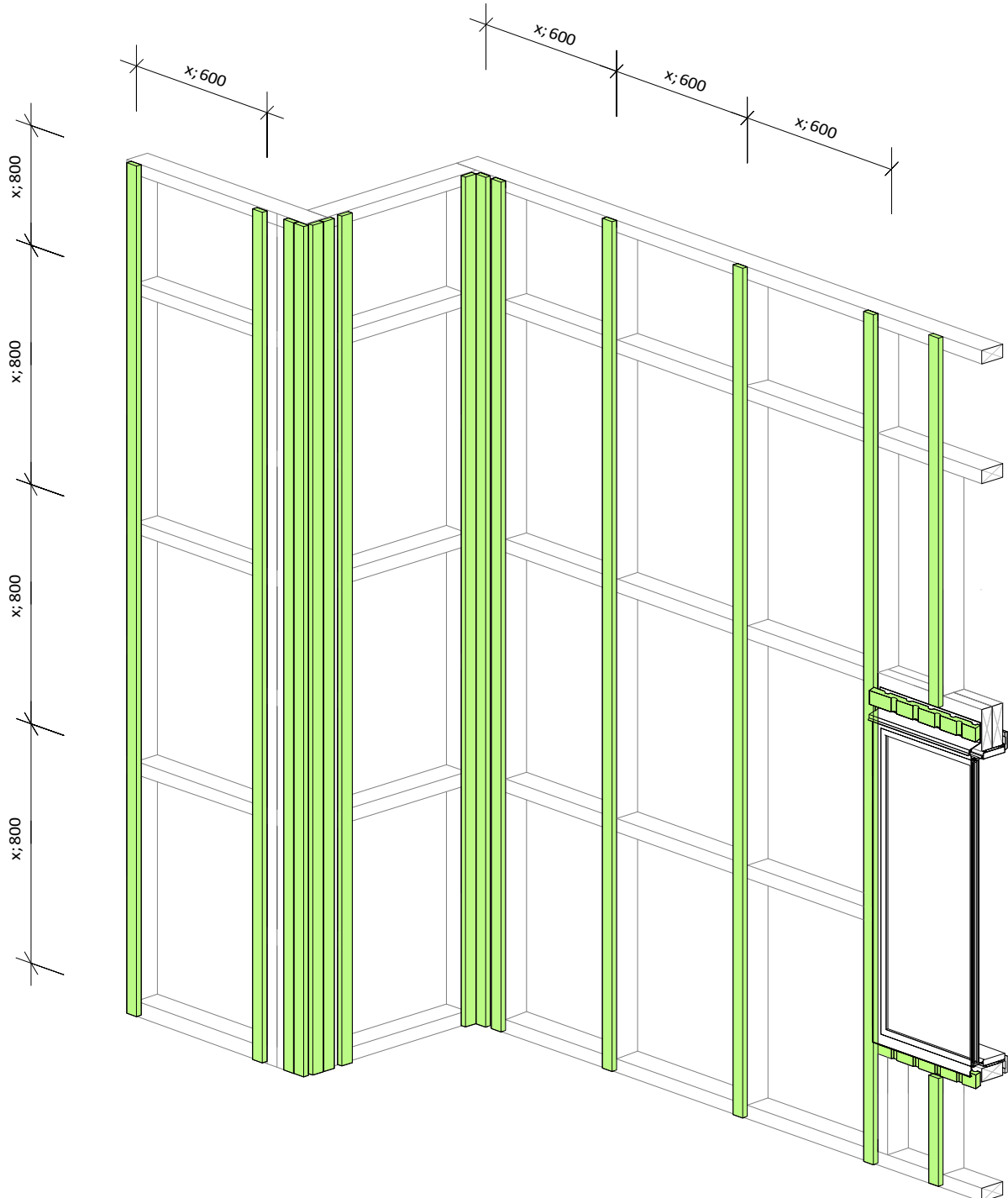

### Contact Details

P: 021 398 800  
E: info@lmatimber.co.nz  
W: www.lmatimber.co.nz  
A: 281 Dyers Road, Bromley, 8062

• TITLE: LMA Bevelback Hardwood Cladding

• DRAWING: Battens Set Out

• SCALE: NTS @A4

• DATE:06/03/2020



**REBATED BEVELBACK  
HARDWOOD CLADDING  
INSTALLATION  
AND MAINTENANCE GUIDE**

## **Material Storage:**

The cladding will be supplied with weatherproof wrap, we recommend this is inspected for damage during transportation and any damage repaired. Packs should be stored on packers to maintain at least 150mm ground clearance, be supported on dry and clean timber bearers at maximum 900 mm centres and stored on a level surface. Once the packing straps are removed the pack should be stropped tight to maintain pack integrity especially if it is to sit for an extended period of time.

The weatherboards must be kept dry at all times either by storing within an enclosed building or when stored externally an additional secondary cover to the plastic wrapping is required. Care must be taken to avoid damage to edges, ends and the weatherboard surfaces.

## **Moisture Content In Timber**

To meet New Zealand MPI / Customs standards, LMA Timbers Australian Hardwood must present at between 9 and 14% moisture content – this is confirmed through kiln dried certification upon custom clearance.

Throughout New Zealand, we have a variance in our EMC (Equilibrium Moisture Content). Timber is affected by this as it is the relative humidity of the air and air temperature it is in contact with causing it to shrink or expand until it finds its equilibrium.

With this in mind, we highly recommend that in order for the timber to acclimatise to its environment and to help ensure minimal movement once installed that it is stored on the actual building site for a number of weeks and filleted (6mm minimum gap between cladding boards) allowing air to freely flow between the boards.

Please ensure to keep the pack stropped tight once filleted to maintain the timbers integrity, especially if it is going to sit for an extended period of time.

## **Substrate prep (Refer Selected LMA Hardwood Cladding Detailing)**

LMA recommends our hardwood cladding is used over a E2 compliant drained and vented cavity system. Timber castellated horizontal cavity battens at 480mm max vertical spacing are recommended. Either 20mm battens fully supported by structural blocking or 40mm+ structural cavity battens are acceptable.

### Installation:

Our preferred fixing is the Würth 70mm x 5.5mm Assy Plus Stainless Steel Self Drilling Decking Screw. 75mm x 3.25mm rose head annular groove S/S or Silica Bronze nails can also be used.. Pre-drilling is advised for both screw and nail options but is a must when closer than 100mm from the end of a board. Refer drawings on pages 27 and 28 of LMA Timber Vertical Shiplap Detailing Documentation. Screws and nails must penetrate a minimum of 30mm into the stud or structural cavity batten.

Placement of fixing is 35-40mm in from lap edge through the full thickness of the board as per our detailing refers.

Clinch nails must be used under the lap to maintain a 2mm expansion gap at the rear face at all times.

### Timber Oiling of Laps, Weather Groove and Back

All 4 sides of the timber including lap joints and ends **must be sealed with oil**, this includes the board lap and weather groove.

LMA timber recommends using Dulux's Intergrain Natures Oil - Natural (tint colour). We have a nationwide deal with Dulux so that you receive up to 20% discount on the recommended retail price. Please use our cash trade account number when purchasing - LMA Timber 139658.

### Joining of boards:

Bottom edges should be cut with an angle of 15deg+ away from the building to create a drip edge **and must be sealed**.

All board joints should be spliced horizontally with a cut angle of 30deg+ with the splice draining to the exterior face and **both cut ends sealed**. An unsupported board overhang of no more than 70mm is recommended. Please refer to page 22 of our Vertical Shiplap Detailing document - Drawing - Scarf Join Stain Finish.

All boards must be fully fixed off within a reasonable time frame to avoid any movement due to moisture exposure and thermal stresses.

## **Maintenance:**

Building owners are responsible for the maintenance of LMA Timbers Hardwood Cladding Systems. Annual inspections must be made to ensure that all aspects of the cladding system, including flashings remain in a weatherproof condition. Any damaged areas or areas showing signs of deterioration which would allow water ingress, must be repaired immediately. Sealant, coatings, flashings or the weatherboards must be repaired in accordance with the relevant manufacturer's instructions.

### **Annual Timber Cleaning**

Regular cleaning (at least annually) of the surface finish with water and a mild detergent is recommended to remove grime, dirt and organic growth (such as mould) to maximise the life and appearance of the cladding.

### **Re-coating of Oil / Stain**

Our Australian Hardwood cladding is a class 1 (majority) or class 2 timber (Silvertop Ash / Fijian Mahogany) as per AS 5604-2005 Timber—natural durability ratings. This means class 1 timber has 40 year plus natural durability and technically does not require further oiling / staining for 15 years as long as our installation and maintenance guidelines are strictly followed.

However, oiling / staining the timber every 2-3 years will increase its durability to in excess of 40 years plus when the oil has a UV stabiliser. It will also help to preserve the original colour of the timber at the time of installation to minimise the silvering off effect due to the strong UV rays we experience in New Zealand.

If no oil / stain is applied over time and the timber has been installed as per the installation guidelines, the timber will naturally silver off without its 15 year durability warranty being compromised.

## **Health and Safety:**

Cutting of LMA Timber cladding must be carried out in well ventilated areas and dust masks, gloves, eye and hearing protection must be worn.



**SHIPLAP WEATHERBOARD  
CLADDING - DURABILITY  
CLASS 1 - 40 YEAR PLUS**



*From: Tripti Singh <Tripti.Singh@scionresearch.com>  
Date: Tuesday, 15 December 2020 at 12:03 PM  
To: Martin Thompson <martin@lmatimber.co.nz>  
Subject: FW: Australian Hardwood Durability - Auckland Council*

*Hi Martin,*

*The most common, naturally durable, Australian Eucalyptus Ironbark spp. are E. paniculata, E. crebra, E. siderophloia. Based on Australian Standard, AS 5604: 2005, the heartwood of Grey Iron Bark has a natural durability rating of Class 1 for both above and in-ground situations and is suitable as a cladding material.*

*Regards*

*Tripti*

*Dr. Tripti Singh*

*Scientist/Project Leader (Bioactives & Wood Protection)*

*Scion*

*49 Sala Street, Private Bag 3020, Rotorua 3046, New Zealand*

*DDI +64 7 343 5329 | Mobile +64 0277427126*

# Durability of New Zealand grown timbers

David Page and Tripti Singh

Data collected over many years and from field sites throughout New Zealand were used to classify the durability of timber from locally grown species. The durability classifications were based on in-ground tests of small stakes. The suitability of individual species for a range of end uses has been measured using a combination of field and 'in-service' tests around the country. These data support the use of naturally durable species as an alternative to preservative treated radiata pine. Suggested uses for the species, their suitability to meet the requirements of NZS 3602 (2003) and likely limitations are discussed.

While the in-ground durability classification provides a useful guide for above-ground uses other factors such as coatings, orientation and exposure to rainfall have a major influence on the durability of components in above-ground situations. Timber from naturally durable species exhibits more variable resistance to decay organisms than that from radiata pine treated commercially with preservatives. We found that the durability classification of some locally grown timbers may be different to that of imported timber of the same species.

There are very few species currently grown in New Zealand that will consistently meet the durability requirements for use as house piles or marine timbers. Hardwoods, particularly eucalyptus species, dominate the list of species suitable for use in moderate-high decay hazard situations such as fence posts and decking where a minimum service life of less than 50 years is required. Timber stability is important in low decay hazard uses such as weatherboards and joinery. Hence softwoods such as cypresses may be preferred for that type of use.

## Durability testing

Naturally durable timber is an attractive alternative to replace or minimise the use of toxic chemical-based biocides for wood protection. Testing of the durability of locally grown timber species and their suitability for various uses in buildings has been carried out at Scion for the past 60 years and is ongoing (FRI, 1982, 1997). Originally samples for testing were taken from the general population of individual species, but more recently some selection has started in an effort to find clones with above-average durability.

## Classification system

Natural durability rating refers to the timber performance both in contact with the ground and above-ground. Durability in New Zealand is measured using the Australasian natural durability classification

system (AS 5604-2003), which classifies timbers into four durability classes:

- Class 1 – very durable
- Class 2 – durable
- Class 3 – moderately durable
- Class 4 – non-durable.

The benchmark testing system used is ground contact stakes, usually 50 or 20 millimetres square. All species are classified on the basis of the heartwood durability because sapwood, regardless of tree species, is non-durable. The proportion of sapwood in a tree may also influence the suitability of a species for particular end uses. For example, Robinia (*Robinia pseudoacacia*) usually has very little sapwood whereas pine species normally have a high sapwood proportion and heartwood of low to moderate durability. Robinia does not therefore require preservative treatment, but timber from pine species requires it before use in outdoor environments.

## Field and in-service tests

In tests conducted by Scion, suitability for various end uses has been measured using a combination of field and in-service tests around the country. These take into account various factors as well as durability such as stability, strength, wear resistance and compatibility with coatings.

Field tests are simulated commodity tests established at Scion field test sites and may include timber from experimental or commercial production. In-service tests involve commercially produced timber components installed in buildings and other structures throughout the country. These field and in-service tests have been used to confirm the suitability of the species for above-ground end uses, as shown in Table 1.

While a particular species may perform well in these tests, other factors such as susceptibility of the growing tree to fungal and insects attack or specific site and establishment requirements could well restrict planting and subsequent utilisation. The list of species tested for durability does not include many timber species grown in this country.

There are many species in parks and small woodlots that are occasionally sawn locally or have yet to become available in commercial quantities. These include *Eucalyptus bosistoana* and some of the other species being grown under the Dryland Forests Initiative – see [www.info@nzdfir.org.nz](http://www.info@nzdfir.org.nz). Many of the indigenous species listed here are now seldom available. Beech species from managed forests and totara from managed woodlots in the far north may be available in small quantities.

Recycled timber from both locally grown and imported species is available sporadically, but when used in exterior situations may be less reliable than freshly cut timber.

Supplies of species other than Douglas fir and radiata pine are often localised and of variable quality. This means that heartwood of a suitable quality for

uses such as joinery, weatherboards and decking is not always available. Territorial authorities may also regard these species as an 'alternative solution' under the building code and require documentation from local tests of strength and durability before they will permit their use.



Far left and above: Field test site located at Whakarewarewa, Scion, Rotorua. Far right: Service test for a locally grown western red cedar building with split shakes on the roof and gable ends

Table 1: In-ground natural durability classification for the heartwood of NZ-grown species (50 mm square stakes)

Class 1 (very durable) >25 years	Class 2 (durable) 15-25 years	Class 3 (moderately durable) 5-15 years	Class 3 (moderately durable) 5-15 years	Class 4 (non-durable) <5 years
<b>Hardwoods</b>	<b>Hardwoods</b>	<b>Hardwoods</b>	<b>Softwoods</b>	<b>Hardwoods</b>
<i>Eucalyptus cladocalyx</i>	<i>E. amygdalina</i>	Black beech <sup>2</sup>	Japanese cedar <sup>2</sup>	<i>Paulownia elongata</i>
Robinia	<i>E. botryoides</i>	Blackwood <sup>2</sup>	Kaikawaka <sup>2</sup>	<i>Paulownia tomentosa</i>
	<i>E. cornuta</i>	<i>E. globulus</i> <sup>2</sup>	Kauri <sup>2</sup>	Poplar
	<i>E. globoidea</i>	<i>E. sieberi</i> <sup>2</sup>	Larch <sup>2</sup>	Tawa
	<i>E. muelleriana</i>	Gleditsia <sup>2</sup>	Lawson cypress <sup>2</sup>	Silver wattle
	<i>E. pilularis</i>	Southern rata <sup>2</sup>	Lusitanica <sup>2</sup>	
<b>Softwoods</b>	<i>E. radiata</i> (p)	<i>E. fastigata</i> <sup>1</sup>	Macrocarpa <sup>2</sup>	<b>Softwoods</b>
Silver pine	<i>E. saligna</i>	<i>E. delegatensis</i> <sup>1</sup>	Matai <sup>2</sup>	<i>P. nigra</i>
Totara	European oak	<i>E. fraxinoides</i> <sup>1</sup>	Redwood <sup>2</sup>	
	Hard beech	<i>E. obliqua</i> <sup>1</sup>	Rimu <sup>2</sup>	
	Mountain beech	<i>E. pyrocarpa</i> <sup>1</sup>	Tanekaha <sup>2</sup>	
	Red beech	<i>E. viminalis</i> <sup>1</sup>	Western red cedar <sup>2</sup>	
	Sweet chestnut	<i>E. regnans</i> <sup>1</sup>	Douglas fir <sup>1</sup>	
		Hinau <sup>1</sup>	Leyland cypress <sup>1</sup> (p)	
		Mangeao <sup>1</sup>	Miro <sup>1</sup>	
		Pukatea <sup>1</sup>	<i>Pinus contorta</i> <sup>1</sup>	
		Silver beech <sup>1</sup>	<i>P. muricata</i> <sup>1</sup>	
			<i>P. radiata</i> <sup>1</sup>	
			<i>P. strobus</i> <sup>1</sup>	
			<i>P. ponderosa</i> <sup>1</sup>	

<sup>1</sup> Species with durability towards the lower end of the range.  
<sup>2</sup> Species with durability towards the upper end of the range.  
 (p) Provisional classification, species still in test.

## Variability associated with exposure conditions

Ground contact durability is influenced by climate and soil conditions – decay is faster in warmer, moist environments. Hence many of the stake durability tests have been duplicated at several sites around the country and results are combined for durability classification.

In above-ground situations there is usually less of a decay hazard than within-ground, but exposure conditions can vary widely. For example, unshaded north-facing walls are exposed to more temperature variations than south-facing walls. Also exposed decking has wide horizontal surfaces that have the potential to absorb and trap more water than the near-vertical surfaces of weatherboards.

The rule of thumb is that a species placed in Class 3 on the basis of stake test results may have an average life similar to Class 2 stakes when used away from ground contact, but this will depend very much on exposure conditions, as shown in Table 2. Coatings, particularly paint coatings, can have a major influence on durability by preventing wetting of the wood. They can have the reverse effect if not well maintained because water

penetrating through breaks in a coating may remain trapped in the wood, increasing the potential for decay.

Table 2: Expected life (years) of naturally durable timbers based on 50 mm or 20 mm square testing samples

Durability Class	Ground contact stakes		Exposed above ground	
	50 mm	20 mm	50 mm	20 mm
Class 1	> 25	> 10	> 40	> 25
Class 2	15 – 25	6 – 10	20 – 40	15 – 25
Class 3	5 – 15	2 – 6	10 – 20	7 – 15
Class 4	0 – 5	0 – 2	0 – 10	0 – 7

Most Class 3 species are only suitable for use away from ground contact. Species in that durability class are loosely divided into two groups, having a durability towards the top or the bottom of the range. Species towards the top of the range are generally suitable for non-structural exterior uses, but those towards the bottom are only suitable for exterior use where they receive some protection from the weather and are in low decay hazard situations.

Table 3: In-ground stake durability variation for three Class 2 eucalyptus species

Species	Tree 1	Tree 2	Tree 3	Tree 4	Tree 5	Average
<i>E. pilularis</i>	13.3 (5 – 21)	6.6 (3 – 13)	10.9 (3 – 17)	5.7 (1 – 12)	10.4 (5 – 12)	9.9
<i>E. muelleriana</i>	10.7 (6 – 20)	6.2 (2 – 16)	6.6 (2 – 15)	8.2 (3 – 13)	9.4 (4 – 18)	9.2
<i>E. globoidea</i>	12.4 (6 – 20)	14.3 (5 – 24)	12.0 (3 – 32)	9.4 (3 – 18)	14.3 (5 – 21)	9.8

### Variability within species

Durability is variable from tree-to-tree of the same species and may be influenced by genetics, growing conditions, climate and wood age, among other factors. An illustration of the type of variation that can be expected within and between species in the same durability class is given in Table 3.

The average life in years for 20 millimetre square heartwood stakes from each tree is shown, with the overall average for the species in this test in the last column. Note that the number of stakes from each tree varied. Figures in parenthesis show the range of durability (in years) for stakes from each tree. For a species to be classified as of Class 2 durability the average life of 20 millimetre square stakes would need to be six to 10 years. The stakes used in this test were all heartwood and were installed in the same plot at the same time. Hence exposure conditions were similar for all groups.

The average life for each species was at the upper end of the range for Class 2 durability, but *E. pilularis* tree 4 was only of Class 3 durability. *E. pilularis* tree 2 and *E. muelleriana* trees 2 and 3 were at the lower end of the Class 2 durability range, whereas three of the *E. pilularis*, one of the *E. muelleriana* and four of the *E. globoidea* trees were of Class 1 durability.

The figures in parenthesis probably best illustrate the variation in durability with some stakes failing after only one or two years. At the other end of the scale, at least one stake from each tree lasted 12 years or more and one *E. globoidea* stake survived for 32 years.

### Suitability for various end uses

Regulations require that timber used in building structural situations should have a minimum life of 50 years. Timber used in non-structural situations should have a minimum life of 15 years if used externally and five years if used internally.

### Ground contact posts, piles and poles

Very few species, including those in the Class 1 durability range, would consistently have a minimum life of 50 years when used in ground contact situations in New Zealand unless they are of large cross-sectional dimensions (more than 200 millimetres). The Australian Timber Service Life Design Guide indicates

that 200 millimetre diameter Class 1 durability poles would have an expected life of 30 to 45 years in south-eastern Australia, an area where the climatic conditions are similar to those in New Zealand. Hence naturally durable species are now seldom used for house piles or poles unless they are supported on steel brackets away from ground contact.

Fence posts have no regulatory minimum life requirement, but 75 to 100 millimetre thick heartwood posts would be expected to last at least 15 years with an average life of 25 to 30 years. Generally Class 1 and Class 2 species will meet this requirement, although occasional failures of Class 2 species inside 15 years are likely.

Split or round posts from young trees are likely to be less reliable than split or sawn posts from mature trees, and in all cases sapwood on posts is likely to rot away within five to 10 years. Species towards the top of the Class 3 range, such as *macrocarpa*, are often used in ground contact situations. The average life of these is likely to be 15 to 20 years, with early failures occurring in five to 10 years.

### Decking and above-ground fence components

These end uses often include moderate-severe decay hazards where timber components are in close contact and in frequently damp situations. The minimum durability requirement for decking is 15 years, but there is no minimum requirement for fence materials. Class 2 species are generally satisfactory for this, although some decay is likely within that time. Thickness may be important because thin (19 millimetre finished thickness) decking of Class 2 species may have an average life of less than 15 years in wetter shaded areas where there is a higher decay hazard.

Class 2 species should be suitable for fence rails and battens, although some decay is likely to develop at rail/post and rail/batten joins in 10 to 15 years. Upper range Class 3 species, such as *macrocarpa*, may be satisfactory as decking in partly protected situations. However occasional failures of individual boards are likely in 10 to 15 years in more exposed situations. Lower range Class 3 species used in these situations, such as Douglas fir, are often unreliable and likely to fail in the five to 15-year timeframe.

Framing for decking is required to have a 50-year minimum life. In situations where it is partly protected

from the weather, framing of Class 2 durability may meet this requirement but earlier failures could be expected where the framing is fully exposed to the weather. Class 1 durable species are more reliable in these situations and in other external structures, such as pergolas, if 50-year durability is a minimum requirement.

## Weatherboards and exterior finishing timbers

These are usually exposed to relatively low decay hazards and are often partly protected by paint or other building elements such as eaves. Stability and appearance are often more important to the eventual service life of these timbers than the durability of the wood. Note that:

- Species in the upper durability range within Class 3 such as the cypresses, western red cedar and redwood are traditional timbers for this type of end use and are relatively stable. Hence heartwood can be used uncoated or stain-coated where a more rustic or 'natural' appearance is desired
- Species in the lower end of the Class 3 range, such as Douglas fir and larch, are less reliable in damp areas and require protection such as paint. Boards containing sapwood should not be used externally unless completely protected from the weather.

## External windows and doors

These are usually exposed to low or moderate decay hazards and are commonly protected by paint coatings. Stability and durability are equally important. Hence species such as imported western red cedar and redwood have often been used for this purpose. Species in the upper section of Class 3, western red cedar, redwood and the cypresses are all suitable for this purpose where timber of a suitable grade is available.

## Specialty uses

- **Marine piles** – timber immersed in saltwater is subject to damage from a variety of marine boring organisms and no locally grown species have shown prolonged resistance to them (Carr, 1953). There are reports of totara and silver pine having a life of more than 10 years in areas where marine borers are less active. Specially preservative treated (Treatment hazard class H6) and a few naturally resistant imported species, for example turpentine (*Syncarpia glomifolia*) from Australia and greenheart (*Ocotea rodiaei*) from tropical America, are the only suitable species for this use.
- **Freshwater timbers** – timber immersed in freshwater usually reaches a moisture content above that at which most decay fungi will attack it. For this reason, sunken logs of non-durable species have remained sound for many years in lakes and rivers. The heartwood of Class 1 and 2 durable species is adequate for most freshwater situations. The section out of the water remains vulnerable to damage by decay fungi. Structural components therefore probably require Class 1

durability if a 50-year life is required and non-structural components Class 2 durability to meet a 15-year minimum requirement.

- **Roof shingles and shakes** – the local traditional species for wooden roof shingles and shakes were totara, kaikawaka and kauri (they were largely replaced by imported western red cedar and Alaskan yellow cedar shingles). Locally grown western red cedar and some of the more durable eucalyptus species, for example *E. saligna*, have been tested as shingles but are less durable and not as stable as the imported species. Quarter-sawn heartwood of locally grown cypresses gave slightly better results, and would probably meet the minimum durability requirement of 15 years on steeper pitched roofs when combined with a well-designed installation system.

## Conclusion

Classification and predication of in-service performances of naturally durable timber is much more difficult than preservative treated timber due to the variability of wood properties within and between trees of the same species and the variable nature of the hazard to which the timber will be exposed. A combination of field test and in-service testing has been used to classify the suitability of locally grown timber for various end-uses and to show that they are a suitable substitute for preservative treated timber.

## Acknowledgements

This is an update of earlier *What's New in Forest Research* FRI Bulletins 112 (1982) and 245 (1997). It is based on data collected by Jackie van-der Waals, Ian Simpson and many earlier members of the Scion Wood Preservation Group.

## References

- Carr, D.R. 1953. Marine Borers in Timber Structures. *New Zealand Engineering*, (Nov): 389-398.
- Forest Research Institute. 1982. The Natural Durability of Untreated Timbers. *What's New in Forest Research*. FRI Bulletin No. 112.
- Forest Research Institute. 1997. Naturally Durable Wood – Is it a Practical Alternative to Preservative Treated Pine? *What's New in Forest Research*. FRI Bulletin No. 245.
- Forest and Wood Products Australia. 2010. *Timber Service Life Design: Design Guide for Durability*. Queensland, Australia.
- Standards Australia. 2003. AS 5604. *Timber – Natural Durability Ratings*. Sydney, Australia: SA.
- Standards New Zealand. 2003. NZS 3602. *Timber and Wood-Based Products for Use in Building*. Wellington, NZ: SNZ.
- Dave Page is Technical Officer and Tripti Singh is Scientist/Project Leader (Bioactives and Wood Preservation) at Scion in Rotorua.*

# Modelling wood processing options for New Zealand: Economic impact analysis

Luke Barry and Peter Hall

## Abstract

A national-level financial model was used in the WoodScape study to analyse the potential of a range of traditional and emerging wood processing technologies. The model inputs industry sourced techno-economic data on wood processing options and macroeconomic impacts from across New Zealand and, where necessary, the rest of the world to assess the increase in GDP, employment and export earnings from processing wood harvested in this country. This identified a number of traditional and emerging technologies, which offer potentially significant increases for both the individual firm and the wider economy. The WoodScape modelling shows that GDP could increase by almost NZ\$1.1 billion per annum, almost 4,500 extra jobs could be created, and export earnings could rise by an estimated NZ\$2 billion. This was estimated by applying a conservative average increase in GDP, employment and export earnings across WoodScape technologies from onshore processing of an extra 11 million cubic metres of typically exported logs. Increased wood processing has an important role in New Zealand's economic growth. The WoodScape study found that most wood processing options can make a significant contribution to GDP. A number of the options also look attractive for investment based on their return on capital (>20 per cent), cash flow and the market opportunity for their products. Several wood processing options show a labour productivity greater than \$200 per hour of employment, comparable to the highest performing sectors of the economy.

## Background

The economic impacts reported here were developed from the WoodScape study. WoodScape (2012) looked at a wide range of wood processing options to determine those that would be likely to perform well in New Zealand based on the operating conditions at the time of the study (2012). An important measure of performance was return on capital employed (ROCE). A summary of the ROCE results from the model used in the study is presented in Figure 1.

This data shows a range of technologies that have ROCE results above 10 per cent. There is a trend for larger-scale operations to perform better than the same technology at a smaller scale. There are a number of engineered wood product, and fuel and chemical, options that look promising although some are not developed to full commercial operations yet.

The ROCE results are highly sensitive to foreign exchange fluctuations as well as product and feedstock price changes. The primary resource considered was the logs which are currently being exported (A and K grade). Additional processing capacity is assumed to be targeted at the export market as the domestic market is largely saturated and cannot absorb the volume of product that could be generated by the development of processing on a scale that could take a substantial proportion of the 2012 export log volume (~13.0 million cubic metres per annum). The export log volume has risen since the original study/report was published and is now ~16 million cubic metres per annum.

The log export market is a crucial outlet for domestic log supply surplus, but the wood processing sector also

has the potential to add significant value to each log harvested. More onshore processing, starting with the initial increases in production and employment from this, will have a multiplicative effect throughout the economy. The purpose of this paper is to quantify and discuss the macroeconomic contribution resulting from increased wood processing across a range of wood processing options.

The scale of the opportunity is significant as New Zealand exported around 50 per cent (~13 million cubic metres per annum) of its ~26.5 million cubic metres per annum log harvest in 2012. Increased onshore processing of this log supply is an important part of the Woodco Strategic Action Plan (SAP). The plan states its goal is to increase export earnings from forestry and wood processing to \$12 billion per annum by 2022, up from its current \$5 billion. These figures for gross export earnings should not be confused with GDP figures, this being a lower figure as it is based on the value added by profitable processing and not the gross income from any processing.

## Macroeconomic multipliers

A macroeconomic impact or effect refers to changes in economic activity in relation to a change in gross output. A macroeconomic multiplier is the ratio of the sum of impacts, for example direct plus indirect, to the direct impact. The effects of an increase in wood processing production in New Zealand are multiple and are generally broken down into three categories:

- **Direct** – additional domestic manufacturing, perhaps as a result of a sustained increase in offshore demand, requires manufacturers to purchase more

Timber is an organic material with a wide variety of physical and mechanical properties. It is important that a timber species is selected which has the properties suitable for its intended use.

The information should be used as a guide only as there can be significant variation within a species.

Plantation grown hardwoods which are becoming more readily available may also have different properties.

This data sheet includes a schedule of the most common timber species available in Australia. Where a species group has been included, the properties scheduled are based on that of the lowest rated species in the group.

For a more comprehensive list of timber species, properties and acceptable uses, refer to Construction Timbers in Queensland (CTIQ) [www.daff.qld.gov.au](http://www.daff.qld.gov.au).

### STANDARD NAME AND BOTANICAL NAME

The names listed in the schedule are those generally defined in AS1148-2001, TIMBER-NOMENCLATURE-AUSTRALIAN, NEW ZEALAND AND IMPORTED SPECIES. However some botanical names have been changed to reflect recent botanical classification changes. Some species may be known by other names in some regions.

### STRENGTH GROUP

Strength Groups are groupings of species with similar properties (e.g. density, strength and modulus of elasticity) in accordance with AS 2878, TIMBERS - CLASSIFICATION INTO STRENGTH GROUPS.

The schedule lists the strength groups **S1** (highest) through to **S7** (lowest) for unseasoned timber, and **SD1** (highest) through to **SD7** (lowest) for seasoned timber.

Visual stress grading of structural members utilise the strength group of the species modified by the strength reducing characteristics (knots, sloping grain etc.) of the particular member.

### JOINT GROUP

The joint group is a classification of species for joint design, based primarily on density. **J1** (unseasoned) and **JD1** (seasoned) species have the highest joint strength properties and **J6** (unseasoned) **JD6** (seasoned) the lowest.

### DENSITY

Density is listed in the schedule for unseasoned (U/S) and seasoned (S) timber. The seasoned density is based on a moisture content of 12%. The unseasoned density is very approximate as it will depend on the moisture content at the time of measurement. It has been provided only as a guide to determine the self weight of an unseasoned member.

### HARDNESS

Hardness is a measure of a species resistance to indentation, wear or abrasion. It also gives an indication of the difficulty of sawing and planing. It is measured in kN and is determined by the Janka hardness test (the higher the number, the greater hardness).

### TOUGHNESS

Toughness is a measure of timbers ability to resist shocks and blows, and is synonymous with impact strength. For the purpose of this schedule, the simplified classifications **L** (low), **M** (medium) and **H** (high) have been adopted.

Specific toughness classifications (Nm) are scheduled in AS 1720.2, SAA TIMBER STRUCTURES CODE PART 2: TIMBER PROPERTIES.

### MOISTURE CONTENT

"Green" timber (when it is freshly sawn) has a very high moisture content. Timber will dry down to the "equilibrium moisture content" of the surrounding environment.

Moisture content influences strength properties, stiffness, hardness, abrasion resistance, machining properties, thermal conductivity, dimensional stability, resistance to decay and nail holding ability.

Moisture content is expressed as a percentage of the weight of water over the oven-dry weight of the wood. For the purpose of this schedule, "Seasoned" timber means having a moisture content of 12%.

### SHRINKAGE

As timber dries, it shrinks. Shrinkage is the percentage reduction in dimension from 'green' (above 25%) to 12% moisture content.

The schedule provides the shrinkage values for the tangential direction. Radial shrinkage is approximately half the tangential. Longitudinal shrinkage in most species is much lower and generally is between 0.1% and 0.3%. However, the effect of grain distortion and reaction wood, such as around knots, can sometimes result in noticeable longitudinal shrinkage.



**Tangential**



**Radial**



**TECHNICAL DATA SHEET**  
ISSUED BY TIMBER QUEENSLAND

**SPECIES, PROPERTIES AND USES**  
**SPECIES TABLES**



RECOMMENDED PRACTICE // MARCH 2014

To be read in conjunction with TDS 16a







## % Unit Tangential Movement (UTM)

Percentage (%) unit tangential movement is the percentage dimensional change for each 1% moisture content change (between 25% and 3% moisture content).

Movement = U.T.M. x (% change in moisture content) x (board width ÷ 100)

## DURABILITY

Durability of timber is the ability to perform its task for a required period of time. This means its performance when exposed to hazards such as decay (fungi) and insects (termites and borers).

Timber species have different natural durability characteristics. Species are given a durability classification based upon their expected service life in the ground or outside above the ground when exposed to hazards.

Class	Rating	Expected Service Life (yrs)	
		In Ground	Outside above Ground
1	High	>25	>40
2	Reasonably High	15-25	15 to 40
3	Moderate	5-15	7 to 15
4	Low	<5	<7

The durability classifications apply to the heartwood (true wood) of a species. The sapwood of all timber, irrespective of species, is not durable and can be regarded as durability Class 4.

The sapwood of most species can be made durable by impregnation with chemicals.

*Note: Only the sapwood of timber can be impregnated and therefore treatment will not change the natural durability of the true wood (heartwood) of a species.*

Species marked '\*' are termite resistant in accordance with AS 3660.1

## LYCTID SUSCEPTIBILITY

The susceptibility of the sapwood of individual hardwood species to attack by lyctid borers is classified as follows:

**S** = Susceptible

**NS** = Not Susceptible

It is recommended that timber containing lyctid susceptible sapwood be treated to a min H1 level in accordance with AS1604.

## FIRE HAZARD PROPERTIES

For interior flooring and lining in Class 2 to 9 Buildings, the Building Code of Australia (BCA) has specific requirements. Refer to TDS 30.

## BUSHFIRE RATED

✓ indicates that untreated timber of this species is rated as a 'bushfire resisting timber' in accordance with AS3959 - Construction of Buildings in Bushfire Prone Areas.

## COLOUR

The colour of seasoned heartwood can vary between species and often within a species. In most cases, the colour of sapwood is either a lighter shade of the heartwood or a white/cream colour. The information in the schedule should be used as a general guide only.

**W** = white, yellow, pale straw to light brown

**P** = pink, to pink brown

**R** = light to dark red

**B** = brown, chocolate, mottled or streaky.

## COMMON USES

The schedule lists common uses of species but not necessarily all uses for which a species is suitable. The listing does not include uses where an individual species is used in a species mix. It assumes that normal good design, workmanship, finishing and maintenance practices will be followed. To ensure compliance with The Building Code of Australia, refer also to CTIQ which is 'called up' for timber used in Queensland.

The schedule includes:-

- (i) **In Ground:**  
Conditions of use include in or on the ground, or in persistently damp or badly ventilated situations, e.g. embedded poles or posts, landscaping timber.
- (ii) **Framing Above Ground - Exposed:**  
Conditions of use include framing exposed to the weather, but clear of the ground and well ventilated, e.g. sub-floor framing to decks, verandah posts etc.
- (iii) **Framing Above Ground - Protected:**  
Fully protected from the weather and other dampness, and well ventilated e.g. wall framing with weatherproof cladding.
- (iv) **Decking:**  
Exposed to weather, clear of the ground and well ventilated, e.g. verandah flooring, boardwalks, wharves.
- (v) **Cladding:**  
Exposed to the weather and clear of the ground.
- (vi) **Internal Flooring:**  
Fully protected from the weather. Consideration may need to be given to species hardness and toughness relative to the specific application.
- (vii) **Panelling:**  
Wall and ceiling linings fully protected from the weather.
- (viii) **External Joinery:**  
Exposed to the weather (or not fully protected), e.g. window sills, external door, window frames, handrails, balusters, stairs and newel posts.
- (ix) **Internal Joinery:**  
Fully protected from the weather, e.g. door jambs, mouldings, internal staircase material, railings.

Uses are indicated as follows:

**O** = commonly used

**P** = commonly used but preservative treated

**S** = commonly used but should be seasoned.

## AVAILABILITY

This schedule provides guidance on availability. This will vary in local areas and with time. Specific advice should be sought from local timber suppliers or Timber Queensland.

**R** = regular

**L** = limited.



**TIMBER  
QUEENSLAND**  
*We build Queensland*

**Timber Queensland Limited**

ACN 092 686 756 | ABN 50 092 686 756

500 Brunswick Street, Fortitude Valley  
Brisbane Queensland 4006

Phone (07) 3254 1989

Fax (07) 3358 7999

PO Box 2014, Fortitude Valley BC Qld 4006

admin@timberqueensland.com.au

[www.timberqueensland.com.au](http://www.timberqueensland.com.au)

Whilst every effort is made to ensure the accuracy of advice given, Timber Queensland Limited cannot accept liability for loss or damage arising from the use of the information supplied.

# GREY IRONBARK



## GREY IRONBARK

GREY IRONBARK IS THE PINNACLE OF VERSATILE AUSTRALIAN HARDWOODS.

This versatility has seen it expand into a new, limitless range of applications including cladding, flooring, decking and joinery products as well as feature posts and beams.

With a deep patina, the colour palette of the Grey Ironbark varies from a mahogany like appearance to pale and dark shades of brown and rich reds.

Suitable for high exposure applications due to its exceptional durability and incredible strength. Grey Ironbark is the top choice for exterior exposed applications.

Today Grey Ironbark is also recognised for its rich, warm colouring and stunning patina, revealing its adaptability and suitability as an internal building material.



<b>COMMON NAME</b>	Grey Ironbark
<b>LOOK &amp; FEATURES</b>	Moderately coarse & even texture, heavy, hard & compact
<b>BOTANICAL NAME</b>	Eucalyptus paniculata Eucalyptus siderophloia
<b>COLOUR</b>	Pale through to dark brown with occasional darker reds
<b>COMMON USES</b>	Cladding, flooring and decking, joinery, feature posts and beams, framework

## PROPERTIES

DENSITY (KG/M3)	
GD	1250
ADD	1100
HARDNESS KN (JANKA)	
Green	11
Dry	16.3
DURABILITY CLASS	1
STRENGTH GROUP	S1/SD1
JOINT GROUP	J1/JD1
SHRINKAGE	
Radial % (approx.)	4.5
Tangential % (approx)	7.5
STRUCTURAL GRADES	
Unseasoned	F14/F17/F22
Seasoned	F27/F34+
TOUGHNESS (NM)	
Green	High
Dry	High
EARLY FIRE HAZARD INDICES	
Ignitability	13
Spread of Flame	3
Smoke Development	3
TERMITE RESISTANT	(toAS3660) Yes
LYCTID SUSCEPTIBLE SAPWOOD	No

# RED IRONBARK



## RED IRONBARK

THE STRENGTH AND DURABILITY OF THIS AUSTRALIAN HARDWOOD HAS SEEN IT USED THROUGHOUT THE AGES AS A PREFERRED STRUCTURAL TIMBER.

Red Ironbark is a very strong Australian hardwood that originated from QLD and NSW. Today Red Ironbark is used for all manner of building construction materials from poles to posts and beams and is ideal for hardwearing areas such as flooring and decking. Whilst being quite hard to work with due to its density and hardness it also polishes to a high sheen and as such is frequently used for furniture, benchtops, bars and even in boat-building.

The heartwood is a deep rich dark red to red-brown in colour. The sapwood by contrast is a pale yellow. The timber's texture is fine with an interlocked grain.



<b>COMMON NAME</b>	Red Ironbark
<b>LOOK &amp; FEATURES</b>	Highly durable with a medium and even texture
<b>BOTANICAL NAME</b>	Eucalyptus sideroxyton, Eucalyptus creba fibrosa
<b>COLOUR</b>	The heartwood colour is deep red. Sapwood is very distinctive, being pale yellow in colour
<b>COMMON USES</b>	A wide range of external applications including heavy engineering, marine structures, poles, sleepers, framework, flooring and decking

## PROPERTIES

DENSITY (KG/M3)	
GD	1200
ADD	1100
HARDNESS KN (JANKA)	
Green	N/A
Dry	11.9
DURABILITY CLASS	
	1
STRENGTH GROUP	
	S2/SD3
JOINT GROUP	
	J1/JD1
SHRINKAGE	
Radial % (approx.)	3.5
Tangential % (approx.)	7
STRUCTURAL GRADES	
Unseasoned	F11/F14/F17
Seasoned	F22/F27
TOUGHNESS (NM)	
Green	High
Dry	Medium/High
EARLY FIRE HAZARD INDICES	
Ignitability	Not available
Spread of Flame	Not available
Smoke Development	Not available
TERMITE RESISTANT (toAS3660)	
	Yes
LYCTID SUSCEPTIBLE SAPWOOD	
	Yes

# TALLOWWOOD



## TALLOWWOOD

HAS A WIDE VARIETY OF USES HOWEVER PARTICULARLY IMPRESSIVE RESULTS ARE ACHIEVED WHEN FEATURED AS INTERNAL FLOORING/ CLADDING AND/OR EXTERNAL FEATURE TIMBERS.

Other applications include decking, linings, exposed structures, poles, bridge timbers, joinery and outdoor furniture. Tallowwood heartwood is pale to yellowish-brown.

This wood has a fairly coarse texture with an interlocking grain. As the word 'tallow' suggests, the timber of this species feels greasy to the touch. Tallowwood is reasonably easy to work however gluing can be difficult due to the greasy nature of the timber. Tallowwood accepts paint, stain and polish readily and fixing with standard fixings and fasteners presents no problems.

Generally, Tallowwood is an extremely tough and durable Australian timber used widely in external applications such as decking.



<b>COMMON NAME</b>	Tallowwood
<b>LOOK &amp; FEATURES</b>	Fairly close-grained timber, free of gum vein
<b>BOTANICAL NAME</b>	Eucalyptus microcorys
<b>COLOUR</b>	Pale to yellowish-brown
<b>COMMON USES</b>	Decking, flooring, cladding, domestic structures, heavy commercial construction, posts, joinery and outdoor furniture

## PROPERTIES

DENSITY (KG/M3)	
GD	1200
ADD	1000
HARDNESS KN (JANKA)	
Green	7.6
Dry	8.6
DURABILITY CLASS	
1	
STRENGTH GROUP	
S2/SD2	
JOINT GROUP	
J1/JD2	
SHRINKAGE	
Radial % (approx.)	4.0
Tangential % (approx.)	6.0
STRUCTURAL GRADES	
Unseasoned	F11/F14/F17
Seasoned	F22/F27
TOUGHNESS (NM)	
Green	Medium
Dry	Medium
EARLY FIRE HAZARD INDICES	
Ignitability	12
Spread of Flame	5
Smoke Development	4
TERMITE RESISTANT	(to AS3660) Yes
LYCTID SUSCEPTIBLE SAPWOOD	Yes

# SPOTTED GUM



## SPOTTED GUM

IS AN EXTREMELY ADAPTABLE AND NATURALLY STRONG TIMBER WHICH MAKES IT IDEALLY SUITED TO NUMEROUS APPLICATIONS.

Once predominantly used only as a structural timber, considering its natural beauty and sheer strength, its not surprising Spotted Gum has found favour in many aesthetic, and architectural applications with extremely impressive results.

Due to its significant versatility and durability you will find Spotted Gum used in a wide variety of applications. From building and construction, including structural components, flooring, cladding, and decking through to furniture (indoor and outdoor), landscaping, poles, beams, the list goes on.

Widely used for power poles, bridge timbers and general construction, Spotted Gum is one of the most widely available Kennedy's in Australia today.



<b>COMMON NAME</b>	Spotted Gum
<b>LOOK &amp; FEATURES</b>	Backsawn grain, Fiddleback, Distinctive sapwood, gum veins
<b>BOTANICAL NAME</b>	Corymbia maculata
<b>COLOUR</b>	Light coffee brown to dark chocolate with some reddish tinges
<b>COMMON USES</b>	Building and construction, structural timbers, flooring, cladding, decking, furniture, landscaping, posts and beams

## PROPERTIES

DENSITY (KG/M3)	
GD	1200
ADD	1100
HARDNESS KN (JANKA)	
Green	8.0
Dry	10.1
DURABILITY CLASS	
1	
STRENGTH GROUP	
S1/SD1	
JOINT GROUP	
J1/JD1	
SHRINKAGE	
Radial % (approx.)	4.5
Tangential % (approx.)	6.0
STRUCTURAL GRADES	
Unseasoned	F11/F14/F17
Seasoned	F22/F27
TOUGHNESS (NM)	
Green	High
Dry	High
EARLY FIRE HAZARD INDICES	
Ignitability	13
Spread of Flame	3
Smoke Development	3
TERMITE RESISTANT	(toAS3660) Yes
LYCTID SUSCEPTIBLE SAPWOOD	Yes

## ASSY® PLUS A2 Decking Screw

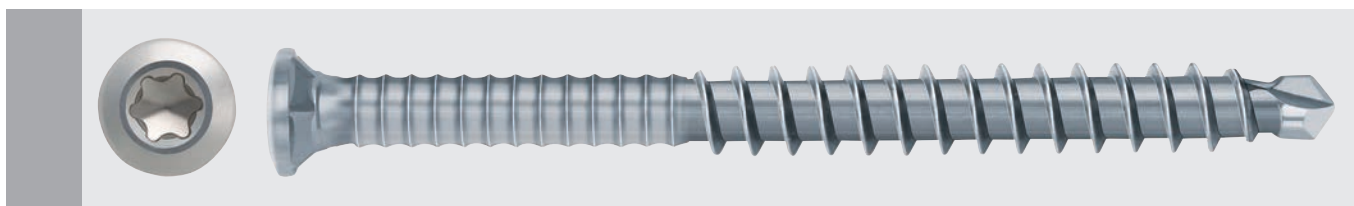

### Pre-drilling is recommended for hardwoods\*.

Material: A2/304

### Small countersunk head with under-head pockets.

- The head can be sunk very easily and cleanly with a small diameter.
- The under-head pockets pick up protruding chips.
- However, with tropical hardwoods, countersinking of the surface is recommended, as the wood has very short chips.

### Grooved shaft.

- Provides for additional screw strength as austenitic stainless steel (A2) cannot be hardened. This virtually eliminates the possibility of the screw tearing off.

### Drilling tip.

- Splitting and tearing of the wood is prevented.

AW drive.

- Excellent snug fit of the bit in the screw drive, which allows the screw to be set very easily.
- Wobbling impacts and sliding of the bit from the screw is prevented when screwing in.

\* Screwing on of hardwood decking planks: Preliminary tests are required for hardwoods. Pre-drilling of the wood may be necessary depending on the density and moisture level of the wood. It is recommended that the processing device be operated at a low speed.

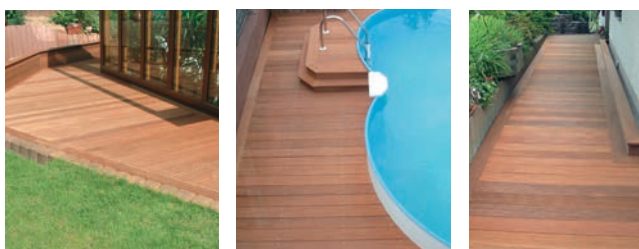

**The screw for fastening decking boards. Many types of wood can be processed without pre-drilling thanks to the drilling tip.**

d mm	L mm	b mm	d <sub>k</sub> mm	Drive	A2/304	P. Qty.
					Art. No.	
5.5	50	27	7.5	AW® 20	0166 115 550	250/1,000
	70	37			0166 115 570	250
	90	38			0166 115 590	100



ETA-11/0190

## ASSY® PLUS Antique Decking Screw



For precise fastening of patio boards. Drill tip allows many types of wood to be processed without pre-drilling. The patio screws are made of A2 stainless steel and are colour-matched to the wood look. They are ideally suited for patio and façade construction outdoors.

d mm	L mm	(d <sub>h</sub> )	Drive	A2/304	P. Qty.
				Art. No.	
5.5	60	7.7	AW® 20	0166 015 560	250
	70			0166 015 570	250

Introduction

Drilling,  
Deburring

Sawing,  
Cutting,  
Abrasive

Lubricating,  
Cleaning,  
Maintenance

Sealing,  
Bonding,  
Painting

Fasteners,  
Fittings,  
Fixings

Safety,  
Protection

Assortments

Hand Tools

# High Performance Pre-oiling Technology



## Introducing the new Intergrain® Industrial Uni Timber Oil.

Uni Timber Oil is a high performance, oil-based timber finish designed for industrial applications. It can be applied to most timber types, and can be top coated on-site with most water-based or oil-based finishes.

### Perfect for home-owners:

- Can be over-coated with most water-based or oil-based decking finishes – no compatibility issues for on-site application
- Deeply penetrating - dries quickly and doesn't feel greasy
- Light pigment offers protection from UV and looks great from day one.

**Material Code:** 702-W0353-200L

For more information on the entire Intergrain range,  
FREECALL 1800 630 285 or visit [intergrain.com.au](http://intergrain.com.au)

Intergrain and Ceetec are registered trademarks.

### Designed for professionals:

- Engineered for industrial coating machines, such as vacuum containers and Ceetec® machines
- Can also be brushed, rolled or sprayed
- Penetrates fast for easy wet stacking and wrapping
- Available in economical 200L drums.

**Intergrain.**

TRADE & INDUSTRIAL

# Next-generation Timber Coating Machine

ENQUIRE ABOUT  
AN ON-SITE  
DEMONSTRATION

## The Ceetec IPT380 is now available in Australia

- ◆ Machine coating capacity of up to 180 lineal metres per minute
- ◆ Built-in touch screen, standard programs, with adjustable brushes and feed speed
- ◆ Uniform quality and four-sided coverage
- ◆ Easy and quick cleaning with optional automatic washing program



Ceetec timber coating machinery is proudly distributed in Australia and New Zealand by Intergrain® Timber Finishes. Intergrain is a registered trademark.

For more information on Ceetec equipment solutions, contact +61 466 421 400.





<b>Health And Safety</b>			
<b>MSDS Number</b>	DLXGHCEN003500	<b>Using Safety Precautions</b>	May cause an allergic skin reaction. May cause drowsiness or dizziness. Keep out of reach of children. Read label before use. Keep away from heat/sparks/open flames/hot surfaces. No smoking. Avoid breathing dust, fume, gas, mist, vapours or spray.. Use only outdoors or in a well-ventilated area. Contaminated work clothing should not be allowed out of the workplace. Wear protective clothing, gloves, eye/face protection and suitable respirator..
<b>Health Effects</b>	FIRST AID: If poisoning occurs, contact a Doctor or Poisons Information Centre (Phone Australia 131 126; New Zealand 0800 764 766). If medical advice is needed, have product container or label at hand. SWALLOWED: If swallowed, do NOT induce vomiting. Give a glass of water. Seek medical advice. EYE: If in eyes, hold eyes open, flood with water for at least 15 minutes and see a doctor. SKIN: If skin contact occurs, remove contaminated clothing and wash skin thoroughly. If irritation occurs seek medical advice. INHALED: Remove from contaminated area. Apply artificial respiration if not breathing. Seek medical advice.	<b>Flammability</b>	Combustible liquid.
<b>Fire Suppression</b>	If material is involved in a fire use water fog (or if unavailable fine water spray), alcohol resistant foam, standard foam, dry agent (carbon dioxide, dry chemical powder).	<b>Protective Equipment</b>	Wear protective clothing, gloves, eye/face protection and suitable respirator.
<b>Storage</b>	Keep out of reach of children.	<b>Disposal</b>	Refer to State/Territory Land Waste Management Authority for disposal
<b>Other</b>	Emergency Tel: Australia – 1800 033 111 New Zealand – 0800 734 607		
<b>In the case of emergency, please call 1800 033 111</b>			

<b>Transport And Storage</b>			
<b>Pack A</b>	702W0353		
<b>Size</b>	<b>Weight</b>		
200	180		
<b>Flash Point</b>	>60C		

**Disclaimer**

Dulux, Selleys and Other marks followed by ® are registered trademarks. Marks followed by the symbol of ™ are trademarks.

The data provided within the Duspec system is correct at the time of publication, however it is the responsibility of those using this information to check that it is current prior to specifying or using any of these coating/product systems.

DISCLAIMER: Any advice, recommendation, information, assistance or service provided by any of the divisions of DuluxGroup (Australia) Pty Ltd or its related entities (collectively, DuluxGroup) in relation to goods manufactured by it or their use and application is given in good faith and is believed by DuluxGroup to be appropriate and reliable. However, any advice, recommendation, information, assistance or service provided by DuluxGroup is provided without liability or responsibility PROVIDED THAT the foregoing shall not exclude, limit, restrict or modify the right entitlements and remedies conferred upon any person or the liabilities imposed upon DuluxGroup by any condition or warranty implied by Commonwealth, State or Territory Act or ordinance void or prohibiting such exclusion limitation or modification. Coating/product systems can be expected to perform as indicated on the Duspec Spec Sheet so long as applications and application procedures of the individual products are followed as recommended on the appropriate Product data Sheet. "DuluxGroup" "Dulux" "Selleys" "Berger" "Berger Gold Label" "Hadrian" "Walpamur" "Levene" "Acratex" and Other marks followed by ® are registered trademarks of DuluxGroup (Australia) Pty Ltd ABN 67 000 049 427. Marks followed by the symbol ™ are trademarks.

Please note that this document is only valid for 60 days from the date of issue.

DuluxGroup (Australia) Pty Ltd 1956 Dandenong Road, Clayton, Victoria 3168 AU ABN 67 000 049 427